



Hilti HSV Stud anchor

Anchor version	Benefits
 <p>HSV Carbon steel with DIN 125 washer</p>	<ul style="list-style-type: none"> ■ torque-controlled mechanical expansion allows immediate load application ■ setting mark ■ cold-formed to prevent breaking during installation ■ raised impact section prevents thread damage during installation ■ drill bit size is same as anchor size for easy installation.
 <p>HSV-BW Carbon steel with DIN 9021 washer and DIN 127b spring washer</p>	



Concrete

Basic loading data (for a single anchor)

All data in this section applies to

- Correct setting (See setting instruction)
- No edge distance and spacing influence
- Concrete as specified in the table
- Steel failure
- Minimum base material thickness
- Concrete C 32/40 $f_{c,cyl} = 32$ MPa

Design resistance

Anchor size	M8		M10		M12		M16	
Effective anchorage depth $h_{ef} \geq$ [mm]	30	40	40	50	50	65	65	80
Tensile N_{Rd} [kN]	5.8	6.7	8.0	9.3	9.7	13.3	16.6	20.8
Shear V_{Rd} [kN]	5.8	6.8	10.8	11.5	15.1	18.1	33.9	33.9

Recommended loads

Anchor size	M8		M10		M12		M16	
Effective anchorage depth $h_{ef} \geq$ [mm]	30	40	40	50	50	65	65	80
Tensile $N_{rec}^{a)}$ [kN]	4.1	4.8	5.7	6.6	6.9	9.5	11.9	14.9
Shear $V_{rec}^{a)}$ [kN]	4.1	4.9	7.7	8.2	10.8	12.9	24.2	24.2

a) With overall partial safety factor for action $\gamma = 1,4$. The partial safety factors for action depend on the type of loading and shall be taken from national regulations.

Materials

Mechanical properties of HSV

Anchor size		M8	M10	M12	M16
Nominal tensile strength	f_{uk} [N/mm ²]	580	660	660	660
Yield strength	f_{yk} [N/mm ²]	464	528	528	528
Stressed crosssection, thread	A_s [mm ²]	36.6	58.0	84.3	157
Stressed crosssection, neck	$A_{s, neck}$ [mm ²]	26.9	39.6	63.6	105.7
Moment of resistance	W [mm ³]	31.2	62.3	109.2	277.5
Char. bending resistance	$M^0_{Rk,s}$ [Nm]	19.5	41.1	72.1	166.5

Material quality

Part	Material
Bolt	Carbon steel, galvanised to min. 5 µm

Anchor dimensions

Anchor size		M8	M10	M12	M16
Shaft diameter at the cone	d_R [mm]	5.85	7.1	9	11.6
Maximum length of the anchor	l_1 [mm]	75	100	150	140
Length of expansion sleeve	l_2 [mm]	15	17.6	20.6	24

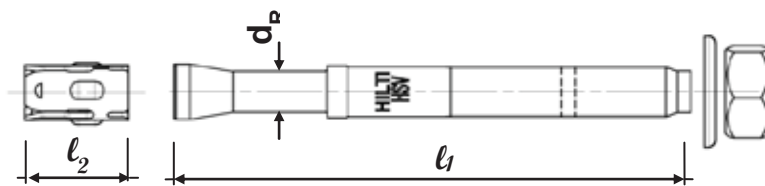

Setting

Anchor size	M8	M10	M12	M16
Rotary hammer	TE1 - TE30			
Other tools	blow out pump, hammer, torque wrench			

Setting instruction

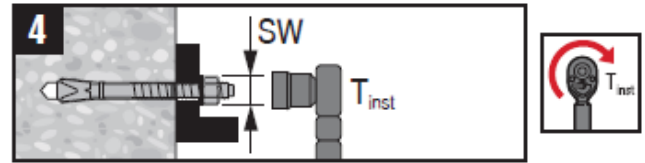
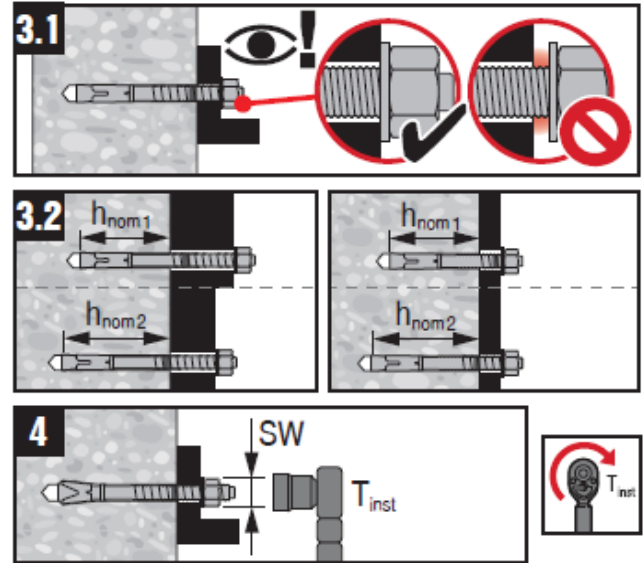
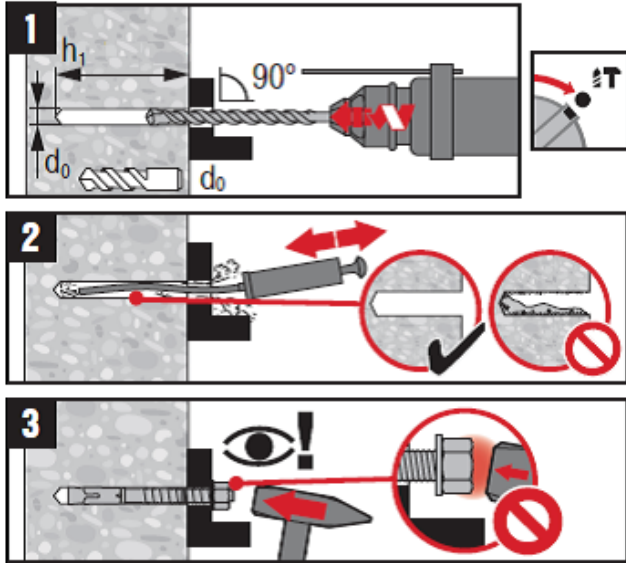

Setting details

Anchor size	M8		M10		M12		M16	
Effective anchorage depth h_{ef} [mm]	30	40	40	50	50	65	65	80
Nominal embedment depth h_{ef} [mm]	39	49	51	61	62	77	81	96
Nominal Diameter of drill bit d_0 [mm]	8		10		12		16	
Cutting diameter of drill bit $d_{cut} \leq$ [mm]	8.45		10.45		12.5		16.5	
Depth of drill hole $h_1 \geq$ [mm]	45	55	60	70	70	85	90	105
Diameter of clearance hole in the fixture $d_f \leq$ [mm]	9		12		14		18	
Minimum thickness of fixture ^{a)} $t_{fix,min}$ [mm]	5	0	5	0	5	0	5	0
Maximum thickness of fixture ^{a)} $t_{fix,max}$ [mm]	20	10	35	25	70	55	35	20
Torque moment T_{inst} [Nm]	15		30		50		100	
Width across nut flats SW [mm]	13		17		19		24	

a) The values are only valid for HSV with standard washer. For HSV-BW with DIN 9021 washer and DIN 127b spring washer the thickness of the fixture has to be reduced.

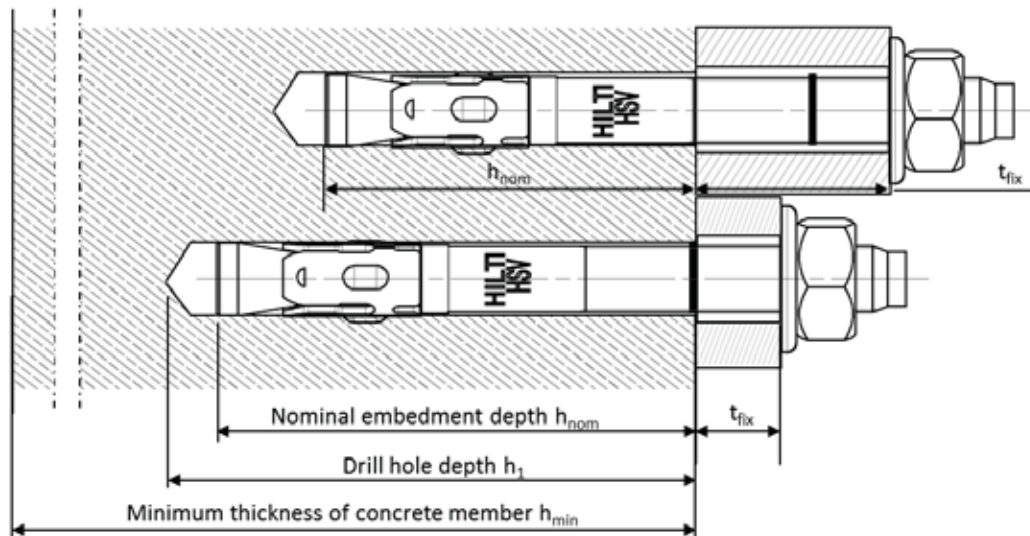

Setting parameters ^{a)}

Anchor size	M8		M10		M12		M16	
Effective anchorage depth h_{ef} [mm]	30	40	40	50	50	65	65	80
Minimum base material thickness $h_{min} \geq$ [mm]	100	100	100	120	140	140	130	170
Minimum spacing $s_{min} \geq$ [mm]	60	60	70	70	80	80	120	100
Minimum edge distance $c_{min} \geq$ [mm]	60	60	70	70	90	90	120	100
Critical spacing for splitting failure $s_{cr,sp}$ [mm]	180	240	240	300	300	390	390	480
Critical edge distance for splitting failure $c_{cr,sp}$ [mm]	90	120	120	150	150	195	195	240
Critical spacing for concrete cone failure $s_{cr,N}$ [mm]	90	120	120	150	150	195	195	240
Critical edge distance for concrete cone failure $c_{cr,N}$ [mm]	45	60	60	75	75	97,5	97,5	120

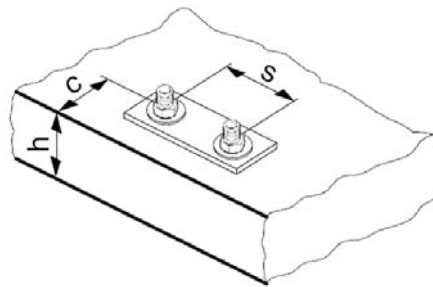

c) In case of smaller edge distance and spacing than $c_{cr,sp}$, $s_{cr,sp}$, $c_{cr,N}$ and $s_{cr,N}$ the load values shall be reduced according ETAG 001, Annex C

Simplified design method

Simplified version of the design method according ETAG 001, Annex C.

- Influence of concrete strength
- Influence of edge distance
- Influence of spacing
- Valid for a group of two anchors. The method may also be applied for anchor groups with more than two anchors or more than one edge. The influencing factors must then be considered for each edge distance and spacing. The calculated design loads are then on the same side: They will be lower than the exact values according ETAG 001, Annex C.

The design method is based on the following simplification:

- No different loads are acting on individual anchors (no eccentricity)

The values are valid for one anchor.

Tension loading

The design tensile resistance is the lower value of

- Steel resistance: $N_{Rd,s}$
- Concrete pull-out resistance: $N_{Rd,p} = N^0_{Rd,p} \cdot f_B$
- Concrete cone resistance: $N_{Rd,c} = N^0_{Rd,c} \cdot f_B \cdot f_{1,N} \cdot f_{2,N} \cdot f_{3,N} \cdot f_{re,N}$
- Concrete splitting resistance (only non-cracked concrete):
 $N_{Rd,sp} = N^0_{Rd,c} \cdot f_B \cdot f_{1,sp} \cdot f_{2,sp} \cdot f_{3,sp} \cdot f_{h,sp} \cdot f_{re,N}$

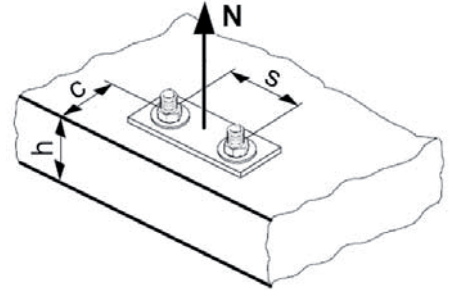

Basic design tensile resistance

Design steel resistance $N_{Rd,s}$

Anchor size		M8		M10		M12		M16	
Effective anchorage depth	h_{ef} [mm]	30	40	40	50	50	65	65	80
$N_{Rd,s}$	[kN]	10,4		17,4		28,0		46,5	

Design pull-out resistance $N_{Rd,p} = N^0_{Rd,p} \cdot f_B$

Anchor size		M8		M10		M12		M16	
Effective anchorage depth	h_{ef} [mm]	30	40	40	50	50	65	65	80
$N^0_{Rd,p}$	[kN]	6,7	6,7	8,0	9,3	9,7	13,3	16,6	20,8

Design concrete cone resistance $N_{Rd,c} = N^0_{Rd,c} \cdot f_B \cdot f_{1,N} \cdot f_{2,N} \cdot f_{3,N} \cdot f_{re,N}$

Design splitting resistance $N_{Rd,sp} = N^0_{Rd,c} \cdot f_B \cdot f_{1,sp} \cdot f_{2,sp} \cdot f_{3,sp} \cdot f_{h,sp} \cdot f_{re,N}$

Concrete C 20/25

Anchor size		M8		M10		M12		M16	
Effective anchorage depth	h_{ef} [mm]	30	40	40	50	50	65	65	80
$N^0_{Rd,c}$	[kN]	4,6	7,1	8,5	11,9	11,9	17,6	14,7	20,1

Influencing factors

Influence of concrete strength

Concrete strength designation (ENV 206)	C 20/25	C 25/30	C 30/37	C 35/45	C 40/50	C 45/55	C 50/60
Pull-out resistance							
$f_B =$	1						
Concrete cone and splitting resistance							
$f_B = (f_{ck,cube}/25N/mm^2)^{1/2 a)}$	1	1,1	1,22	1,34	1,41	1,48	1,55

a) $f_{ck,cube}$ = concrete compressive strength, measured on cubes with 150 mm side length

Influence of edge distance ^{a)}

$c/c_{cr,N}$	0,1	0,2	0,3	0,4	0,5	0,6	0,7	0,8	0,9	1
$c/c_{cr,sp}$										
$f_{1,N} = 0,7 + 0,3 \cdot c/c_{cr,N} \leq 1$										
$f_{1,sp} = 0,7 + 0,3 \cdot c/c_{cr,sp} \leq 1$	0,73	0,76	0,79	0,82	0,85	0,88	0,91	0,94	0,97	1
$f_{2,N} = 0,5 \cdot (1 + c/c_{cr,N}) \leq 1$										
$f_{2,sp} = 0,5 \cdot (1 + c/c_{cr,sp}) \leq 1$	0,55	0,60	0,65	0,70	0,75	0,80	0,85	0,90	0,95	1

a) The edge distance shall not be smaller than the minimum edge distance c_{min} given in the table with the setting details. These influencing factors must be considered for every edge distance.

Influence of anchor spacing ^{a)}

$s/s_{cr,N}$	0,1	0,2	0,3	0,4	0,5	0,6	0,7	0,8	0,9	1
$s/s_{cr,sp}$										
$f_{3,N} = 0,5 \cdot (1 + s/s_{cr,N}) \leq 1$										
$f_{3,sp} = 0,5 \cdot (1 + s/s_{cr,sp}) \leq 1$	0,55	0,60	0,65	0,70	0,75	0,80	0,85	0,90	0,95	1

a) The anchor spacing shall not be smaller than the minimum anchor spacing s_{min} given in the table with the setting details. This influencing factor must be considered for every anchor spacing.

Influence of base material thickness

h/h_{ef}	2,0	2,2	2,4	2,6	2,8	3,0	3,2	3,4	3,6	$\geq 3,68$
$f_{h,sp} = [h/(2 \cdot h_{ef})]^{2/3}$	1	1,07	1,13	1,19	1,25	1,31	1,37	1,42	1,48	1,5

Influence of reinforcement

Anchor size	M8		M10		M12		M16	
Effective anchorage depth h_{ef} [mm]	30	40	40	50	50	65	65	80
$f_{re,N} = 0,5 + h_{ef}/200\text{mm} \leq 1$	0,65 ^{a)}	0,7 ^{a)}	0,7 ^{a)}	0,75 ^{a)}	0,75 ^{a)}	0,825 ^{a)}	0,825 ^{a)}	0,9 ^{a)}

c) This factor applies only for dense reinforcement. If in the area of anchorage there is reinforcement with a spacing ≥ 150 mm (any diameter) or with a diameter ≤ 10 mm and a spacing ≥ 100 mm, then a factor $f_{re,N} = 1$ may be applied.

Shear loading

The design shear resistance is the lower value of

- Steel resistance: $V_{Rd,s}$
- Concrete pryout resistance: $V_{Rd,cp} = k \cdot N_{Rd,c}$
- Concrete edge resistance: $V_{Rd,c} = V_{Rd,c}^0 \cdot f_B \cdot f_{lB} \cdot f_h \cdot f_4 \cdot f_{hef} \cdot f_c$

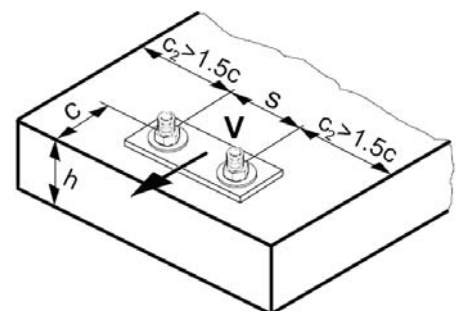

Basic design shear resistance

Design steel resistance $V_{Rd,s}$

Anchor size	M8		M10		M12		M16	
Effective anchorage depth h_{ef} [mm]	30	40	40	50	50	65	65	80
$V_{Rd,s}$ [kN]	6,8		11,5		18,1		33,9	

Design concrete pryout resistance $V_{Rd,cp} = k \cdot N_{Rd,c}$ ^{a)}

Anchor size	M8		M10		M12		M16	
Effective anchorage depth h_{ef} [mm]	30	40	40	50	50	65	65	80
k	1				2			

a) $N_{Rd,c}$: Design concrete cone resistance

Design concrete edge resistance $V_{Rd,c} = V_{Rd,c}^0 \cdot f_B \cdot f_{\beta} \cdot f_h \cdot f_4 \cdot f_{hef} \cdot f_c$

Anchor size	M8		M10		M12		M16	
Effective anchorage depth h_{ef} [mm]	30	40	40	50	50	65	65	80
$V_{Rd,c}^0$ [kN]	9,1	9,0	13,0	13,0	17,6	17,6	28,3	28,2

a) For anchor groups only the anchors close to the edge must be considered.
Concrete C 20/25

Influencing factors

Influence of concrete strength

Concrete strength designation (ENV 206)	C 20/25	C 25/30	C 30/37	C 35/45	C 40/50	C 45/55	C 50/60
$f_B = (f_{ck,cube}/25N/mm^2)^{1/2}$ ^{a)}	1	1,1	1,22	1,34	1,41	1,48	1,55

a) $f_{ck,cube}$ = concrete compressive strength, measured on cubes with 150 mm side length

Influence of angle between load applied and the direction perpendicular to the free edge

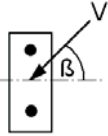
Angle β	0°	10°	20°	30°	40°	50°	60°	70°	80°	≥ 90°
$f_{\beta} = \frac{1}{\sqrt{(\cos \alpha_V)^2 + \left(\frac{\sin \alpha_V}{2,5}\right)^2}}$ 	1	1,01	1,05	1,13	1,24	1,40	1,64	1,97	2,32	2,50

Influence of base material thickness

h/c	0,15	0,3	0,45	0,6	0,75	0,9	1,05	1,2	1,35	≥ 1,5
$f_h = \{h/(1,5 \cdot c)\}^{1/2} \leq 1$	0,32	0,45	0,55	0,63	0,71	0,77	0,84	0,89	0,95	1,00

Influence of anchor spacing and edge distance ^{a)} for concrete edge resistance: f_4

$$f_4 = (c/h_{ef})^{1,5} \cdot (1 + s / [3 \cdot c]) \cdot 0,5$$

c/h _{ef}	Single anchor	Group of two anchors s/h _{ef}														
		0,75	1,50	2,25	3,00	3,75	4,50	5,25	6,00	6,75	7,50	8,25	9,00	9,75	10,50	11,25
0,50	0,35	0,27	0,35	0,35	0,35	0,35	0,35	0,35	0,35	0,35	0,35	0,35	0,35	0,35	0,35	0,35
0,75	0,65	0,43	0,54	0,65	0,65	0,65	0,65	0,65	0,65	0,65	0,65	0,65	0,65	0,65	0,65	0,65
1,00	1,00	0,63	0,75	0,88	1,00	1,00	1,00	1,00	1,00	1,00	1,00	1,00	1,00	1,00	1,00	1,00
1,25	1,40	0,84	0,98	1,12	1,26	1,40	1,40	1,40	1,40	1,40	1,40	1,40	1,40	1,40	1,40	1,40
1,50	1,84	1,07	1,22	1,38	1,53	1,68	1,84	1,84	1,84	1,84	1,84	1,84	1,84	1,84	1,84	1,84
1,75	2,32	1,32	1,49	1,65	1,82	1,98	2,15	2,32	2,32	2,32	2,32	2,32	2,32	2,32	2,32	2,32
2,00	2,83	1,59	1,77	1,94	2,12	2,30	2,47	2,65	2,83	2,83	2,83	2,83	2,83	2,83	2,83	2,83
2,25	3,38	1,88	2,06	2,25	2,44	2,63	2,81	3,00	3,19	3,38	3,38	3,38	3,38	3,38	3,38	3,38
2,50	3,95	2,17	2,37	2,57	2,77	2,96	3,16	3,36	3,56	3,76	3,95	3,95	3,95	3,95	3,95	3,95
2,75	4,56	2,49	2,69	2,90	3,11	3,32	3,52	3,73	3,94	4,15	4,35	4,56	4,56	4,56	4,56	4,56
3,00	5,20	2,81	3,03	3,25	3,46	3,68	3,90	4,11	4,33	4,55	4,76	4,98	5,20	5,20	5,20	5,20
3,25	5,86	3,15	3,38	3,61	3,83	4,06	4,28	4,51	4,73	4,96	5,18	5,41	5,63	5,86	5,86	5,86
3,50	6,55	3,51	3,74	3,98	4,21	4,44	4,68	4,91	5,14	5,38	5,61	5,85	6,08	6,31	6,55	6,55
3,75	7,26	3,87	4,12	4,36	4,60	4,84	5,08	5,33	5,57	5,81	6,05	6,29	6,54	6,78	7,02	7,26
4,00	8,00	4,25	4,50	4,75	5,00	5,25	5,50	5,75	6,00	6,25	6,50	6,75	7,00	7,25	7,50	7,75
4,25	8,76	4,64	4,90	5,15	5,41	5,67	5,93	6,18	6,44	6,70	6,96	7,22	7,47	7,73	7,99	8,25
4,50	9,55	5,04	5,30	5,57	5,83	6,10	6,36	6,63	6,89	7,16	7,42	7,69	7,95	8,22	8,49	8,75
4,75	10,35	5,45	5,72	5,99	6,27	6,54	6,81	7,08	7,36	7,63	7,90	8,17	8,45	8,72	8,99	9,26
5,00	11,18	5,87	6,15	6,43	6,71	6,99	7,27	7,55	7,83	8,11	8,39	8,66	8,94	9,22	9,50	9,78
5,25	12,03	6,30	6,59	6,87	7,16	7,45	7,73	8,02	8,31	8,59	8,88	9,17	9,45	9,74	10,02	10,31
5,50	12,90	6,74	7,04	7,33	7,62	7,92	8,21	8,50	8,79	9,09	9,38	9,67	9,97	10,26	10,55	10,85

a) The anchor spacing and the edge distance shall not be smaller than the minimum anchor spacing s_{min} and the minimum edge distance c_{min} .

Influence of embedment depth

Anchor size	M8		M10		M12		M16	
Effective anchorage depth h_{ef} [mm]	30	40	40	50	50	65	65	80
$f_{hef} = 0,05 \cdot (h_{ef} / d)^{1,68}$	0,46	0,75	0,51	0,75	0,55	0,85	0,53	0,75

Influence of edge distance ^{a)}

c/d	4	6	8	10	15	20	30	40
$f_c = (d / c)^{0,19}$	0,77	0,71	0,67	0,65	0,60	0,57	0,52	0,50

a) The edge distance shall not be smaller than the minimum edge distance c_{min} .

Combined tension and shear loading

For combined tension and shear loading see section "Anchor Design".