



Operating instructions

en

3 x 480V

DS TS20-E 1.6

ORIGINAL OPERATING INSTRUCTIONS

DS TS20-E 1.6 3×480 V electric wall saw

Contents	Page
1. General safety rules	4
2. Specific safety rules and symbols	6
3. Functional description	11
4. Assembly	14
5. Operation	23
6. Maintenance	27
7. Troubleshooting	29
8. Accessories	33
9. Manufacturer's warranty – tools	34

It is essential that the operating instructions are read before the machine is operated for the first time. Always keep these operating instructions together with the machine. Ensure that the operating instructions are with the machine when it is given to other persons.

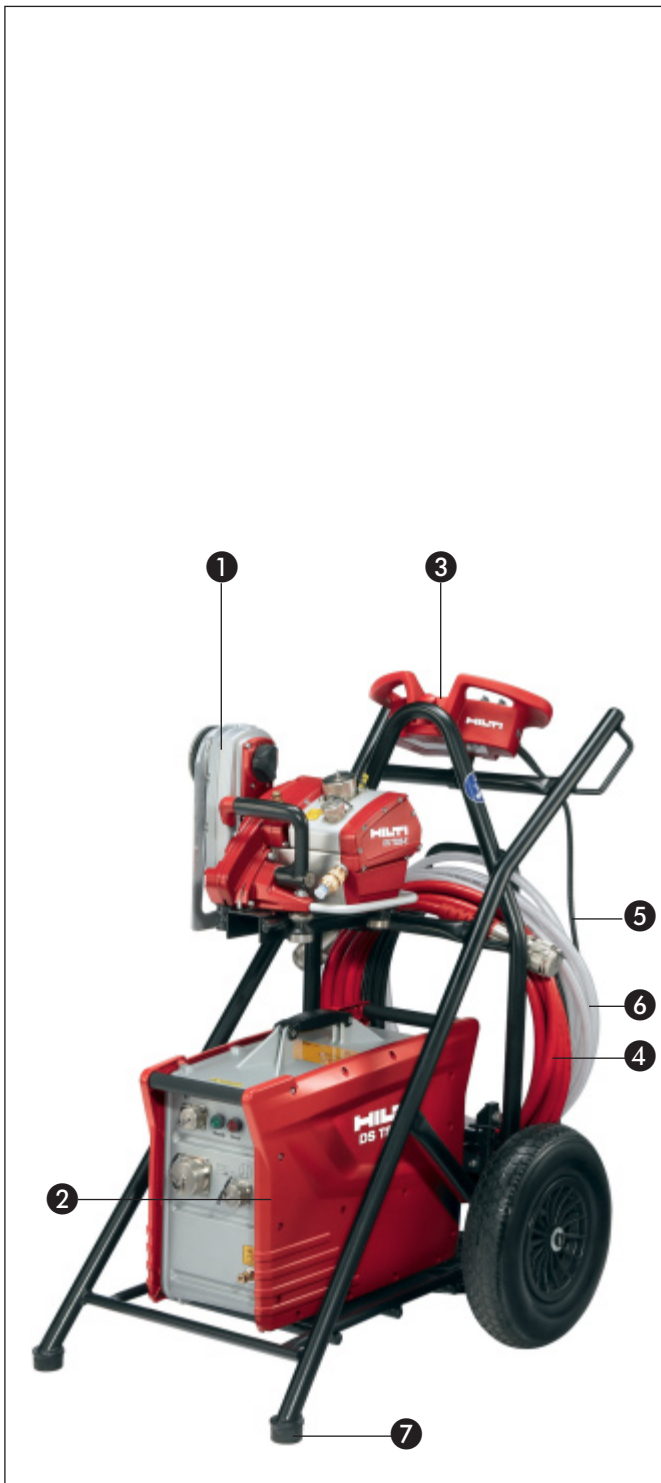

- ① Saw head
- ② Power supply
- ③ Remote control unit
- ④ Power cable
- ⑤ Control cable
- ⑥ Water hose
- ⑦ Transport trolley – saw head



- ⑧ Blade guard - center section
- ⑨ Blade guard – side section
- ⑩ Guide rail with end stop
- ⑪ Accessory box with rail support and toolbox
- ⑫ Transport trolley - accessories

General safety rules

1. General safety rules

1.1 **WARNING!** Read and understand all instructions. Failure to follow all instructions listed below may result in electric shock, fire and/or serious personal injury.

SAVE THESE INSTRUCTIONS

1.2 Work Area

Keep your work area clean and well lit. Cluttered benches and dark areas invite accidents.

Do not operate power tools in explosive atmospheres, such as in the presence of flammable liquids, gases, or dust. Power tools create sparks which may ignite the dust or fumes.

Keep bystanders, children and visitors away while operating a power tool. Distractions can cause you to lose control.

1.3 Electrical Safety

Grounded tools must be plugged into an outlet properly installed and grounded in accordance with all codes and ordinances. Never remove the grounding prong or modify the plug in any way. Do not use any adaptor plugs. Check with a qualified electrician if you are in doubt as to whether the outlet is properly grounded. If the tools should electrically malfunction or break down, grounding provides a low resistance path to carry electricity away from the user.

Applicable only to Class I (grounded) tools.

Avoid body contact with grounded surfaces such as pipes, radiators, ranges and refrigerators. There is an increased risk of electric shock if your body is grounded.

Don't expose power tools to rain or wet conditions. Water entering a power tool will increase the risk of electric shock.

Do not abuse the cord. Never use the cord to carry the tools or pull the plug from an outlet. Keep cord away from heat, oil, sharp edges or moving parts. Replace damaged cords immediately. Damaged cords increase the risk of electric shock.

When operating a power tool outside, use an outdoor extension cord marked «W-A» or «W». These cords are rated for outdoor use and reduce the risk of electric shock.

1.4 Personal Safety

Stay alert, watch what you are doing and use common sense when operating a power tool. Do not use a tool while tired or under the influence of drugs, alcohol, or medication. A moment of inattention while operating power tools may result in serious personal injury.

Dress properly. Do not wear loose clothing or jewelry. Contain long hair. Keep your hair, clothing, and gloves away from moving parts. Loose clothes, jewelry, or long hair can be caught in moving parts.

Avoid accidental starting. Be sure switch is off before plugging in. Carrying tools with your finger on the switch or plugging in tools that have the switch on invites accidents.

Remove adjusting keys or wrenches before turning the tool on. A wrench or a key that is left attached to a rotating part of the tool may result in personal injury.

Do not overreach. Keep proper footing and balance at all times. Proper footing and balance enables better control of the tool in unexpected situations.



Use safety equipment. Always wear eye protection. Dust mask, non-skid safety shoes, hard hat, or hearing protection must be used for appropriate conditions.

1.5 Tool Use and Care

Use clamps or other practical way to secure and support the workpiece to a stable platform. Holding the work by hand or against your body is unstable and may lead to loss of control.

Do not force tool. Use the correct tool for your application. The correct tool will do the job better and safer at the rate for which it is designed.

Do not use tool if the switch does not turn it on or off. Any tool that cannot be controlled with the switch is dangerous and must be repaired.

Disconnect the plug from the power source before making any adjustments, changing accessories, or storing the tool. Such preventive safety measures reduce the risk of starting the tool accidentally.

Store idle tools out of reach of children and other un-

trained persons. Tools are dangerous in the hands of untrained users.

Maintain tools with care. Keep cutting tools sharp and clean. Properly maintained tools with sharp cutting edges are less likely to bind and are easier to control.

Check for misalignment or binding of moving parts, breakage of parts and any other condition that may affect the tools operation. If damaged, have the tool serviced before using. Many accidents are caused by poorly maintained tools.

Use only accessories that are recommended by the manufacturer for your model. Accessories that may be suitable for one tool may become hazardous when used on another tool.

1.6 Service

Tool service must be performed only by qualified repair personnel. Service or maintenance performed by unqualified personnel could result in a risk of injury.

When servicing a tool, use only identical replacement parts. Follow instructions in the Maintenance section of this manual. Use of unauthorized parts or failure to follow Maintenance Instructions may create a risk of electric shock or injury.

Specific safety rules and symbols

2. Specific safety rules and symbols



WARNING

Failure to observe the instructions listed below may lead to potentially fatal injury and serious damage to property or equipment.

2.1 Proper organization of the work area

a) Approval must be obtained from the site engineer or architect prior to beginning drilling or sawing work. Drilling or sawing work on buildings and other structures may influence the statics of the structure, especially when steel reinforcing bars or load-bearing components are cut through.

b) Ensure that the workplace is well ventilated. Exposure to dust at a poorly ventilated workplace may result in damage to the health.

c) Keep the workplace tidy. Objects which could cause injury should be removed from the working area. Untidiness at the workplace can lead to accidents.

d) In order to avoid injury and to prevent the diamond blade becoming trapped or jammed, steel wedges and/or supports must be used to prevent uncontrolled movement of parts of the structure being cut.

e) Ensure that adequately-sized supports are correctly installed so that the remaining structure maintains its stability after completion of the cutting work and removal of the part cut away.

f) Never loiter in the vicinity of loads suspended by cranes.

g) The area of the cut or the opening created by the cutting process must be safely and visibly cordoned off in order to avoid the possibility of persons falling.

h) Wear personal protective equipment. Wear safety shoes or boots, protective gloves, a hard hat, ear protection and eye protection.

i) Wear respiratory protection if the work causes dust.

j) Keep children and other persons away from the working area.

k) Do not allow other persons to touch the machine or the extension cord.

l) Avoid unfavorable body positions. Make sure you work from a safe stance and stay in balance at all times.

m) To avoid presenting a tripping hazard, always ensure that cables and hoses leading to the machine are laid flat on the floor.

n) Keep cables and hoses away from rotating parts.

o) In cooperation with the site engineer or architect, ensure that no gas, water, electricity or other supply lines are located in the cutting area. Any supply pipes or cables located close to the cutting area present a serious hazard if damaged while the work is in progress. External metal parts of the machine could become live if, for example, an electric supply cable is damaged.

p) Ensure that the cooling water used is drained or extracted in a suitably controlled manner. Water that is allowed to drain away or spray around in an uncontrolled manner can lead to damage or accidents. The fact that water could drain away into internal, hidden cavities, e.g. in brickwork or masonry, must also be taken into account.

q) Do not work from a ladder.

r) The machine is not intended for use by children, by debilitated persons or those who have received no instruction or training.

s) Children must be instructed not to play with the machine.

t) Dust from material such as paint containing lead, some wood species, minerals and metal may be harmful. Contact with or inhalation of the dust may cause allergic reactions and/or respiratory diseases to the operator or bystanders.

Certain kinds of dust are classified as carcinogenic such as oak and beech dust especially in conjunction with additives for wood conditioning (chromate, wood preservative). Material containing asbestos must only be treated by specialists.

Where the use of a dust extraction device is possible it shall be used. To achieve a high level of dust collection, use a suitable vacuum cleaner of the type recommended by Hilti for wood dust and/or mineral dust together with this tool. Ensure that the workplace is well ventilated. The use of a dust mask of filter class P2 is recommended. Follow national requirements for the materials you want to work with.

2.2 Safety measures at the danger areas

Safety measures must be implemented in the area where sawing is taking place to ensure that operators and bystanders cannot be injured or property damaged by debris that may fly off or fall down (broken-off diamond segments, small stones, sawing slurry, etc.) while sawing is in progress. Safety measures must also be implemented in the area not directly visible to the operator, i.e. behind where sawing is taking place.

Persons must NEVER enter the danger area 10 feet (3 meters) – in all directions from the line of the cut to be made – while the blade drive is switched on.

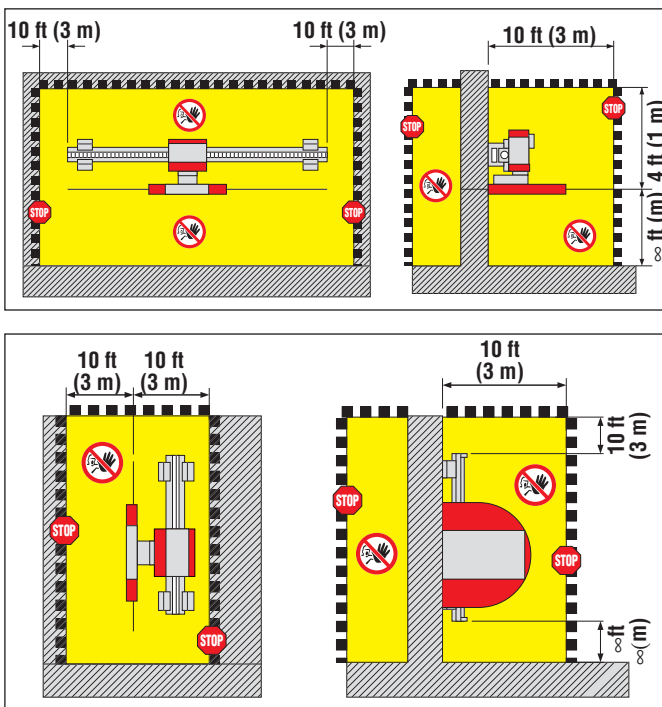

CAUTION

Secure the working area. Ensure that no persons can be injured or property / equipment damaged by falling objects or debris that may fly off during the sawing operation.

1. Approval must be obtained from the site engineer or site management before beginning the sawing work.
2. Find out whether overcutting at corners is permitted. If not, the corresponding corner holes must be planned and drilled first.
3. Check that the area is cordoned off, that supports are in place and warnings to third parties are displayed.

When setting up and operating the saw system and when removing parts that have been cut away, always ensure that no persons are below the area in which you are working. Falling objects could cause serious injury.

2.3 Electrical safety

- a) Check the machine's supply cord at regular intervals and have it replaced by a qualified specialist if found to be damaged. Check extension cords at regular intervals and replace them if found to be damaged.
- b) Check the condition of the machine and its accessories. Do not operate the machine and its accessories if damage is found, if the machine is incomplete or if its controls cannot be operated faultlessly.
- c) Do not touch an electric cable that has been damaged while working. Switch off at the main switch and unplug the cable at the power outlet.
- d) Damaged or faulty switches must be replaced at a Hilti service center. Do not use the machine if it cannot be switched on and off correctly.
- e) Have the machine repaired only by a trained electrical specialist (Hilti service center) using genuine Hilti spare parts. Failure to observe this point may result in risk of accident to the user.
- f) Do not use the supply cord for purposes for which it is not intended. Never carry the machine by the supply cord. Never pull the plug out of the power outlet by pulling the supply cord.
- g) Do not expose supply cords to heat, oil or sharp edges.
- h) Connect the machine and its ancillary equipment only to a power source equipped with an earth/ground conductor and ground fault circuit breaker (PRCD). Check that these items are in perfect working order before operating the equipment. Install an earth/ground rod if a generator is used or if no earth/ground conductor is present in the on-site electric supply. Operation of the machine without an earth/ground connection is not permissible under any circumstances. If in doubt about a correct earth/ground connection in the power supply, the E-box must be grounded with the ground connection provided on the E-box. With no earth/ground connection, faulty insulation on a part of the machine or inadvertently sawing into a live cable presents a risk of fatal accident.
- i) Make sure that the mains voltage corresponds to the specification given on the type plate.
- j) Electric cables and their plug connectors must be kept dry. When not in use, close power outlets with the cover provided.

Specific safety rules and symbols

k) Use only extension cables which have an adequate conductor cross-section and are approved for the intended field of use. Do not work with extension cables when they are rolled up. This can result in a drop in output at the equipment and may cause the cable to overheat.

l) Disconnect the power cable before beginning cleaning and maintenance work or in the event of a lengthy interruption between periods of operation.

m) Please note that certain components of the power converter retain an extremely dangerous (potentially fatal) high voltage for up to 10 minutes after disconnection from the electric supply.

2.4 Requirements to be met by users

a) The machine shall be operated only by specialists trained in concrete cutting techniques, referred to in the following as “operators”. These persons must be familiar with the content of these operating instructions and must have been trained in their safe application by a Hilti specialist.

b) The user and any other persons in the vicinity must wear suitable eye protection, a hard hat, ear protection, protective gloves and safety footwear while the equipment is in use.

2.5 Safety during operation

Check that the wall saw and its components, the saw blade and all accessories are in good condition and in perfect working order before use. Any damage or malfunctions must be rectified in a PROFESSIONAL manner before operation commences.

Position the electric power supply outside the danger area.

Sawing may begin only once the wall saw system (rail supports) have been fastened securely to a solid surface and the other parts of the system have been assembled or installed correctly (all bolts tightened, the saw head positioned securely on the rail, locking levers closed, end stops fitted). A falling object could result in serious personal injury or damage to property or equipment.

NEVER stand in the direction of radial flight of a run-

ning saw blade. Always use the appropriate blade guard (DS-BG for normal cutting, DS-BGF for flush cutting).

Always operate the machine from the closed side of the blade guard, i.e. the protected side, when corner cuts are made with the blade guard in the partly open position. The operator must take additional precautions (fit a cover, plank of wood, boards etc.) where necessary.

Never enter the danger area (e.g. to change the saw blade, remove the blade guard side section, hammer in wedges, etc.) before the blade drive is switched off and the blade has come to a standstill. Press the Output Stop switch before entering the danger area.

Do not touch rotating parts.

Observe the permissible drive unit parameters, blade rotation speed and advance speed while sawing.

Use only saw blades which have been approved for the use at a peripheral cutting speed of at least 80 m/sec. Fit the blades the right way round (observe correct direction of rotation).

Use of blades with laser-welded segments can reduce the risk of segments breaking and flying off.

Check the blade mounting flange and blade for damage (e.g. cracks in the steel disc) and degrease the blade mount each time before operating the wall saw.

Always put on gloves before touching the saw blade as it can get hot.

Use only fastening materials of adequate size (anchors, bolts, etc.) to fasten the rail supports.

Use only the accessories recommended in these operating instructions. Use of other accessories may result in personal injury or damage.

If equipment such as scaffolding, platforms or ladders is used, check that this equipment complies with regulations, that it is undamaged and set up in accordance with regulations.

The operator must take measures to ensure that no persons enter or loiter in the danger area at any time while the saw is in operation. This also applies to the area not immediately visible to the operator, i.e. the area behind or below the object in which the cut is being made. If necessary, a large area must be cordoned off or security personnel posted.

Stay alert at all times. Monitor the progress of the sawing operation and keep an eye on the cooling water system and the area surrounding the workplace. Do not operate the machine if your full attention is not on the job.

No modifications may be made to the saw system. Modification of the factory-set drive parameters is strictly prohibited.

2.6 Safety instructions for transporting the equipment

Avoid lifting and carrying heavy objects. Use suitable lifting equipment and means of transport and share heavy loads between several people.

Use the handles provided for transportation. Always keep the handles clean and free of grease.

Bear in mind that the machine could fall over. Stand it only on a solid, level surface.

Make sure that the saw system and its components cannot move about or fall over during transportation.

The machine may be lifted by crane only at the lifting points provided using tested and approved lifting gear. Before lifting, check that all removable items of equipment are securely attached to the two transport trolleys or locked in position. Never loiter under loads suspended by crane.

2.7 Explanation of warning signs and other symbols

DANGER

Draws attention to imminent danger that could lead to serious bodily injury or fatality.

WARNING

Draws attention to a potentially dangerous situation that could lead to serious personal injury or fatality.

CAUTION

Draws attention to a potentially dangerous situation that could lead to slight personal injury or damage to the equipment or other property.

NOTE

Draws attention to instructions and other useful information.

Warning signs



General warning



Warning: electricity

Obligation signs



Wear eye protection.



Wear a hard hat.



Wear protective gloves.



Wear safety footwear.



Wear respiratory protection.



Wear ear protection.

Symbols



Read the operating instructions before use.



A	V	Hz	mm	/min	rpm	n
Amps	Volts	Hertz	Millimeters	Revolutions per minute	Revolutions per minute	Rated no-load speed



- Removing cooling water from the saw head and power supply
1. Connect the blow-out adapter to the hose on the HIT pump.
 2. Blow out the saw head 7 times with the HIT pump.
 3. Blow out the power supply at the water outlet 4 times with the HIT pump.

Specific safety rules and symbols



The saw head and accessory transport trolleys may be lifted by crane only at the lifting points provided.

Before transport, all items of equipment must be secured to prevent movement or falling.

Never loiter in the vicinity of loads suspended by cranes.

Use only tested and approved lifting gear.

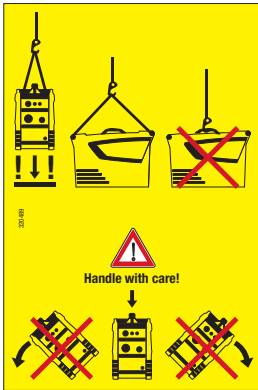

The power supply may be lifted by crane only at the lifting points provided.

Never loiter in the vicinity of loads suspended by cranes.

Use only tested and approved lifting gear.



The transport trolley may become unstable or run away if stood on an inclined surface.



Do not touch metal parts of saw head and E-box during operation except main switch at E-box.

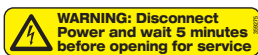

Before opening the E-box for service disconnect the E-box from electric power supply wait 5 minutes to allow the capacitors to discharge

2.8 Other information

In these operating instructions, the DS TS20-E electric wall saw is referred to as “**the machine**”.

Location of identifying data on the machine

The type designation, item number, serial number, year of manufacture and technical status can be found on the rating plate on the machine.

Make a note of this data in your operating instructions and always refer to it when making an enquiry to your Hilti representative or service department.

Power supply:

Type: DS EB-TS20

serial no. _____

Saw head:

Type: DS TS20-E

serial no. _____

Remote control unit:

Type: DS RC-TS20

serial no. _____

2.9 Disposal of drilling and sawing slurry

- With regard to environmental aspects, allowing drilling or sawing slurry to flow directly into rivers, lakes or the sewerage system without suitable pre-treatment is problematical.
- In addition to the following recommended pre-treatment procedures, the applicable national regulations must be observed when disposing of drilling or sawing slurry. Ask the local authorities concerned for further information.

We recommend the following pre-treatment

- Collect the drilling and sawing slurry (e.g. using a suitable industrial vacuum cleaner).
- The fine content of the drilling and sawing slurry should be separated from the water by allowing it to settle (e.g. leave standing for some time or add a coagulation agent).
- Solid material from the drilling and sawing slurry should be deposited at a construction waste
- Water from the drilling and sawing slurry should be neutralized (e.g. by adding a large quantity of water or other neutralization agents) before it is allowed to flow into the sewerage system.

3. Functional description

3.1 Use of the equipment as intended

1. The DS TS20-E is an electrically-powered, rail-guided wall saw designed for cutting lightly to heavily-reinforced concrete, stone or masonry structures with diamond saw blades of 24" to 64" (600 mm to 1600 mm) in diameter – maximum blade diameter for initial cut: 32" (825 mm).
2. All functions of the machine are controlled by an electric remote control unit. The speed of rotation of the saw blade can be controlled smoothly and steplessly between 0 and maximum speed.
3. The saw blade drive motor provides a constant power output. Saw advance can be controlled manually and/or automatically. Thanks to load-dependent advance control, the saw is very easy to operate. The saw operates virtually fully automatically at the maximum power set on the control unit.
4. Best sawing performance is achieved when the DS TS20-E is used with the specially-matched Hilti DS-B wall saw blades. For diameters up to 48" use only diamond wall saw blades which have been approved for use at a perimeter speed of at least 63 m/s, for diameters larger than 48" use only blades that have been approved for at least 80 m/s.
5. Use only anchors of adequate size and load capacity to secure the machine to the object to be cut.
6. Do not cut materials that may release hazardous or explosive dust or vapors during the cutting process. Do not cut inflammable materials.
7. Overhead sawing is possible when additional precautionary measures are taken. For this application, the blade guard must be equipped with a means of water drainage. Care must be taken to ensure that no persons are present beneath the equipment when sawing overhead. Please consult your Hilti representative for further information and advice.
8. Use only genuine Hilti accessories (available as options) for angled or stepped cuts or for flush cutting.
9. Always check that the electric supply provided at the construction site is equipped with an earth/ground conductor and a ground fault circuit interrupter (PRCD

type A, trigger current max. 30 mA) and that these are connected.

3.2 Items supplied as standard

The items supplied on the saw head trolley include:

- Saw head
- Power supply
- Remote control unit
- Power and control cables
- Cooling water hose
- Transport trolley
- Tool set
- Operating instructions

The items supplied on the accessories trolley include:

- Blade guard for 36" (900) mm dia. saw blade
- Rail supports (4 supports)
- Transport box
- Transport trolley

Using the accessories listed, the wall saw can be adapted to suit the particular conditions of the application you intend to carry out.

Functional description

3.3 Technical data for the DS TS20-E power supply*

	DS EB-TS20 3 × 480 V	
Rated voltage	480 V ~	
Mains frequency	60 Hz	
Pin assignment	3P+PE	
Rated current	22 A	
Mains fuse rating max.	30 A	
Power input, max.	25 hp	19 kW
Generator power rating, min.	40 kVA @ 30 A	
Ground fault circuit breaker in supply	30 mA (type A)	
Cooling water temperature at 4l/min.	39 to 86° F	4 to 30°C
Cooling water pressure min. / max.	29 to 87 psi	2 to 6 bar
Protection class ****	IP 65	
Weight	84 lb	38 kg
Dimensions l × w × h	28.7 × 13.8 × 23.2''	73 × 35 × 59 cm
Operating / storage temperature	5 to 122° F ***	-15°C to +50°C ***
Operating / ambient temperature	5 to 113° F ***	-15°C to +45°C ***
Leakage current	≤ 10 mA	
Insulation resistance	at least 300 k Ω	

3.4 Technical data for the DS TS20-E saw head*

DS TS20-E

Motor power S1**	20 hp	15 kW
Drive spindle speed	100 to 940 r.p.m.	
Protection class ****	IP 65	
Saw blade diameter	24'' to 64''	600 mm to 1600 mm
Max. cutting depth	29''	73 cm
Weight	82 lb	37 kg
Dimensions l × w × h	14.8 × 17.3 × 12.6''	37.5 × 44 × 32 cm
Operating / storage temperature	5 to 122° F ***	-15°C to +50°C ***
Operating / ambient temperature	5 to 113° F ***	-15°C to +45°C ***

3.5 Technical data for the DS TS20-E remote control unit

	DS RC-TS20 remote control unit	
Cable length	33 ft	10 m
Voltage	24 V DC	
Protection class ****	IP 65	
Weight	4.85 lb	2,2 kg
Dimensions l × w × h	15.4 × 7.5 × 4.9''	390 × 190 × 125 mm

* Rated values guaranteed at max. 64° F (18°C) and heights of up to 2,000 m above sea level.

** Continuous operation 100%

*** At temperatures below zero, allow the machine to warm up slowly before subjecting to load and drain (blow out) the water from the cooling circuit after use (a pump is supplied for this purpose).

**** Protection class IP65 in accordance with EN 60529, 6 = protection against entry of dust, 5 = protection against water jets (hose proof)

3.6 Technical data for the transport trolleys

	Saw head trolley	Accessory trolley
Dimensions loaded, L × W × H	41.7 × 29.5 × 42.4" 1060 × 750 × 1080 mm	41.7 × 29.5 × 55.1" 1060 × 750 × 1400 mm*
Weight loaded **	267.9 lb 121.5 kg	200.7 lb 91 kg
Max. permissible total weight	330.8 lb 150 kg	330.8 lb 150 kg

* With 3.3 ft (1 m) rail. Height with 7.5 ft (2.3 m) rail = 97" (245 cm).

** Contents in accordance with list of items supplied, see section 2.2

3.7 Type plates

HILTI DS TS20-E 1.6 01
HILTI = trademark of HILTI Corporation, Schean, LI Made in Liechtenstein

WALL SAW SYSTEM

Serial number **3** — 0000000

Prim. in	480 V	60 Hz	22 A	3~ + PE
n _o =	100 - 940 rpm			

WARNING:
TO REDUCE THE RISK OF INJURY, USER MUST READ AND UNDERSTAND INSTRUCTION MANUAL

1 **2** **4**

FFE	ETL	DATE
359270	01	08

HILTI INC. TULSA, OK 74145

HILTI DS EB TS20-E 1.6 01
HILTI = trademark of HILTI Corporation, Schean, LI Made in Austria

POWERSUPPLY

Serial number **3** — 0000000

Sec.out 1	360 V	100-1000 Hz	28 A	
Sec.out 2	360 V	10-600Hz	0,7A	

WARNING:
TO REDUCE THE RISK OF INJURY, USER MUST READ AND UNDERSTAND INSTRUCTION MANUAL

1 **2** **4**

FFE	ETL	DATE
344570	02	13

HILTI INC. TULSA, OK 74145

HILTI DS TS20-E 1.6 01
HILTI = registered trademark of HILTI Corp. Schean/LI Made in Liechtenstein

SAW HEAD

Serial number **3** — 0000000

Prim.in 1	360V	100-1000Hz	28A	n _o 1=100-940rpm
Prim.in 2	360V	10-600Hz	0,7A	n _o 2= 0-20rpm

max. Ø63" / 1600 mm

WARNING:
TO REDUCE THE RISK OF INJURY, USER MUST READ AND UNDERSTAND INSTRUCTION MANUAL

1 **2** **4**

FFE	ETL	DATE
361930	01	09

HILTI INC. TULSA, OK 74145

HILTI DS RC TS20-E 1.6 02
HILTI = trademark of HILTI Corporation, Schean, LI Made in Austria

REMOTE CONTROL

Serial number **3** — 0000000

24 V	===			
------	-----	--	--	--

WARNING:
TO REDUCE THE RISK OF INJURY, USER MUST READ AND UNDERSTAND INSTRUCTION MANUAL

1 **2** **4**

FFE	ETL	DATE
368455	01	08

HILTI INC. TULSA, OK 74145

- 1** = Engineering number
- 2** = Spare parts list index
- 3** = Serial number
- 4** = Year of manufacture

4. Preparations at the workplace

4.1 Planning the cutting sequence, marking the cutting line and fastening points

1. The parts to be cut out are usually marked by the client. A rational cutting sequence can be followed when the rail supports are cleverly positioned.
2. If necessary, adjust the size and weight of the concrete blocks to the prevailing conditions by making dividing cuts (i.e. depending on the work order, the means of handling the blocks, the crane or the maximum floor loading capacity and size of doors).
3. Use steel wedges and supports, as necessary, to secure the sections of concrete while sawing.

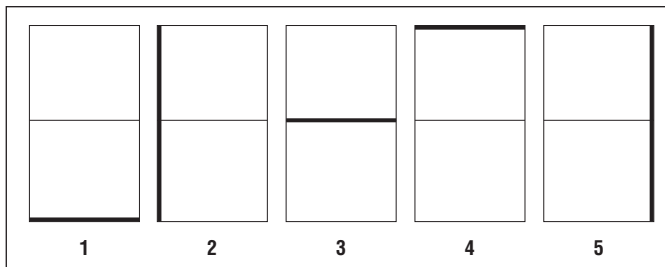

4.2 Clarifying the situation and securing the workplace

Have you made sure there are no hazardous pipes or cables (gas, water, electricity etc.) in the cutting area?

Have the effects of the cutting work on the stability of the structure been clarified and are the supports in place capable of taking up the resulting loads?

Can the possibility of hazards or damage as a result of the cooling water used be ruled out?

Have safety measures been implemented to ensure that no persons can be injured or property and equipment damaged by falling objects or debris that may fly off during the sawing operation?

Can the parts of the structure that are to be sawn out be removed safely in a controlled operation and subsequently disposed of?

Does the electric supply and water supply available for use meet the specified requirements?

Is the required equipment in the correct specification available for use?

Has the work to be carried out been approved in full by the site engineer or architect?

4.3 Electric power supply / fuse rating

CAUTION

Irrespective of whether using mains power or generator power, always check that an earth/ground conductor and ground fault circuit breaker are present in the power supply and that these are connected. If in doubt about a correct earth/ground connection in the power supply, the E-box must be grounded with the ground connection provided on the E-box. The fuse rating of the electric power supply at the construction site must be as follows:

Voltage version	3 × 480 V
Maximum fuse rating	30 A
Ground fault circuit breaker (FI)	Type A 30 mA

4.4 Electric power connection / power cable plugs

Voltage version	3 × 480 V
Pin assignment	3 Pole, 4 Wire Grounding (3P+PE)

Pin assignment

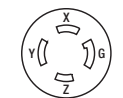

30A 3Ø 480V AC
NEMA L16-30P
UL/CSA
10 HP

X = phase 1, Y = phase 2, Z = phase 3, G = earth / ground (PE)

The power supply cable supplied with the tool has to be used to connect the tool to the local power supply.

The remote control unit indicates the voltage and shows an error in the event of any one of the phases (X, Y, Z) providing no power.

4.5 Extension cables / conductor cross section

- Use only extension cables which are approved for the intended field of use and with conductors of adequate cross section.
- For extension cables use following cable specification and minimum conductor cross sections: cable extra hard type for wet and outdoor locations, 4 wires AWG10, 3P+PE, 480 V / 30 A (conductor cross section = cross-sectional area of individual conductors).
- Inadequate conductor cross sections and long cables result in a drop in voltage and may cause the cable to overheat.

- Extension cables must be fully unrolled before the wall saw is put into operation.

4.6 Cooling water supply

1. When the cooling water has a temperature of 64° F (18°C), a flow rate of approx. 1.06 gallon/min (4 l/min) is required for cooling the power supply and saw head.
2. Use only clean cooling water.
3. In applications with a minimal water flow rate (e.g. masonry), the excess water can be drained away by using the bypass function at the saw head.
4. The machine's automatic cut-out will be activated in the event of inadequate cooling.
5. Where pressure in the water supply line is low, a non-return valve should be fitted in order to prevent dirty water finding its way into the water supply.

NOTE

In order to prevent damage to the seals, a small quantity of water is allowed to reach the saw blade by way of the drive spindle even when the bypass valve is fully closed.

4.7 Connecting the power supply

NOTE

Operating the main switch several times in quick succession will cause the electric supply to be temporarily interrupted. Wait for a few seconds before switching on again.

1. Set the current input limiter to the corresponding fuse rating.
2. Connect the power cable ④ (observe the information on the type plate ⑦).
3. Remove the protective cap and connect and secure the remote control unit ⑤.
4. Close the protective caps ⑤ by fitting them together.
5. Move the main switch ③ to the "I" position. The "Ready" indicator ② then lights.
6. Connect the external cooling water hose ⑥. Water pressure must not exceed 6 bar.

Parts

No. Designation

①	Error indicator (red)
②	"Ready" indicator (green)
③	Main switch
④	Power cable connector
⑤	Socket for remote control unit

- | | |
|---|---------------------------------|
| ⑥ | Cooling water connection (feed) |
| ⑦ | Type plate |
| ⑧ | Plug for saw head control cable |
| ⑨ | Plug for saw head power cable |
| ⑩ | Cooling water connection (exit) |
| ⑪ | Ground connection |



Assembly

4.8 Fastening the rail supports

CAUTION

- Failure to observe the spacing shown may cause the saw to wander off course and, in extreme situations, may result in failure of the anchor fastenings.
- Adequately dimensioned and correctly installed fastenings are essential in order to ensure efficient and safe operation of the equipment.
- For fastening to uncracked concrete, we specify Hilti HDI flush anchors or anchors of a type with at least equal loading capacity (observe the manufacturer's anchor-setting instructions).
- The construction materials and conditions encountered at the location where sawing is to be carried out vary from site to site. Should you be unsure of the strength of the supporting material and have doubts about the solidity of the fastening obtained, please contact Hilti Customer Service for technical advice.

NOTE

- During installation, the leveling screws should not project beyond the contact surface of the rail supports.
- Use the DS-RFP rail support for angled and stepped cuts.

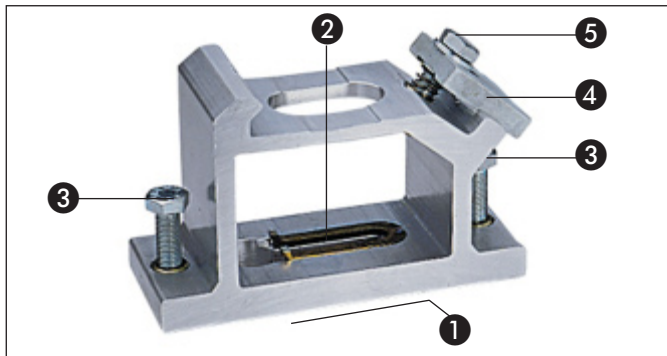

Rail support for regular cutting

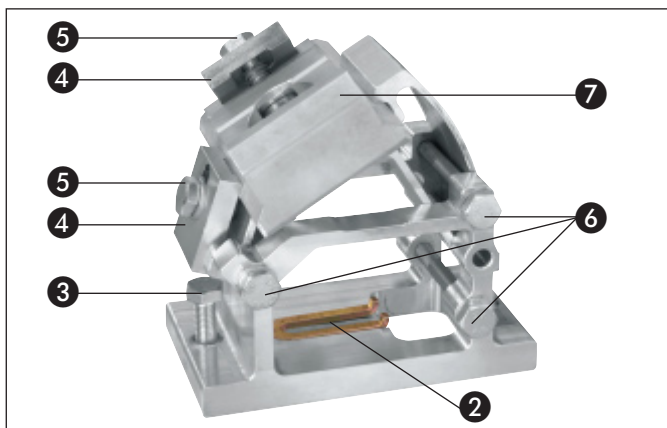

Rail support for angled and stepped cutting

Parts

No.	Designation
①	Contact surface
②	Anchor slot for fitting rail support
③	Leveling screws
④	Rail clamping plate
⑤	Rail clamping screw
⑥	Clamping screw for angle adjustment
⑦	Clamping plate for stepped cuts



1. Mark the positions of the anchor holes for the rail supports.
2. Drill the anchor holes (depth and diameter in accordance with the manufacturer's instructions).
3. Clean the holes (remove the drilling dust).
4. Insert and expand the anchors (e.g. Hilti HDI) using the setting tool.
5. Screw in the fastening screws (8.8 grade with collar nut, supplied in the accessory box) to their full depth by hand.
6. Position and align the rail supports and then tighten the collar nuts slightly.

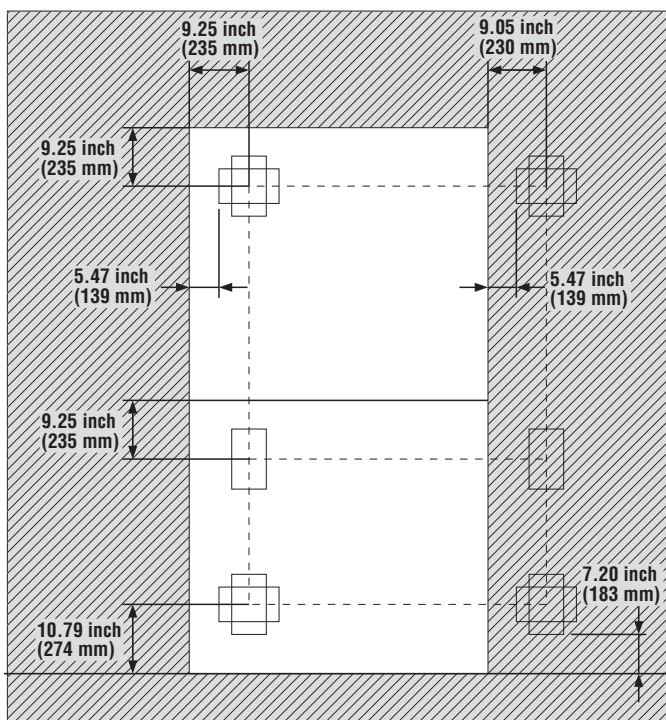

Anchor hole distance

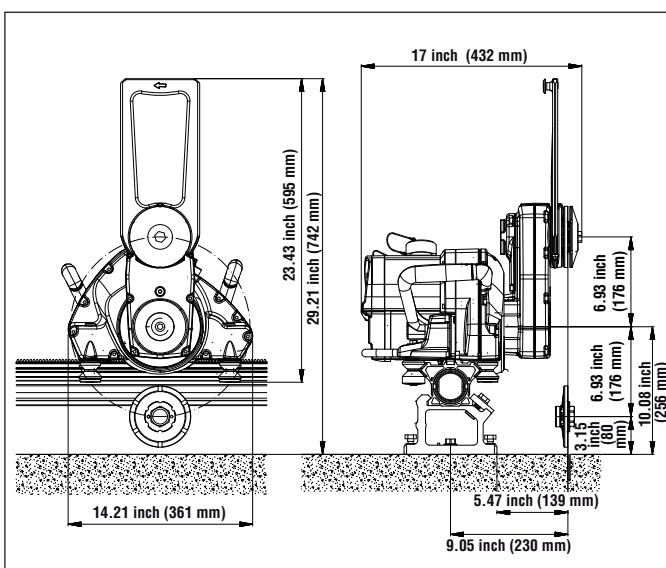

Main dimensions of the DS TS20-E (in inch / mm)

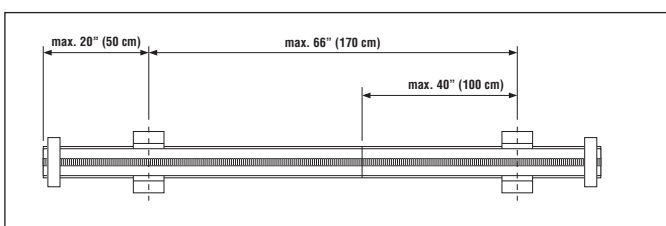

Maximal permissible rail support distance

4.9 Fitting the rail

1. Fit the rail clamp to the rail.
2. Position the rail with fitted rail clamp on the rail support and close the clamping plate.
3. Turn the rail support until at right angles to the rail and then tighten the clamping plate securely.
4. Compensate for any difference in level by adjusting the leveling screws.
5. Align the rail at the correct distance from the cutting line and then tighten the fastening screws.
6. Fit end stops at both ends of the rail.

NOTE

The rail clamps cannot be used with the rail supports for angular cutting.



Parts

No. Designation

①	Rail
②	Rail clamp
③	Rail support
④	Rail clamping plate
⑤	Rail clamping screw
⑥	Leveling screws
⑦	Clamping plate for stepped cuts

Assembly

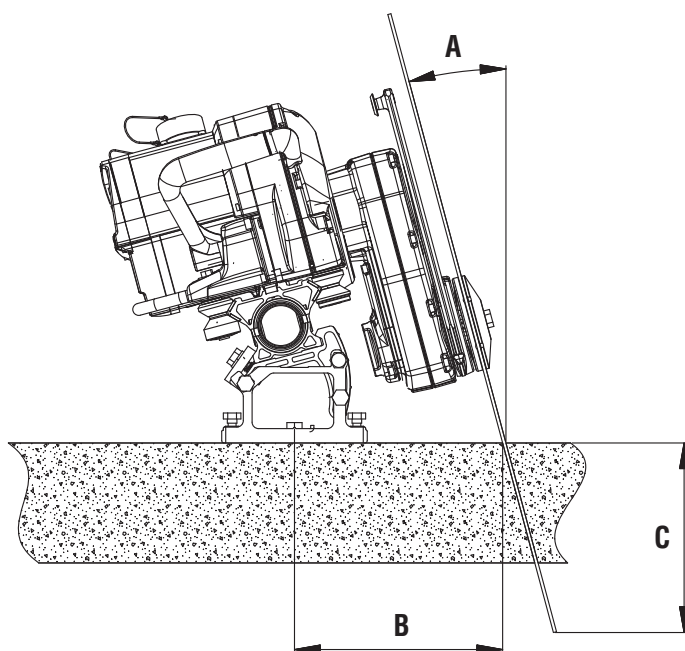
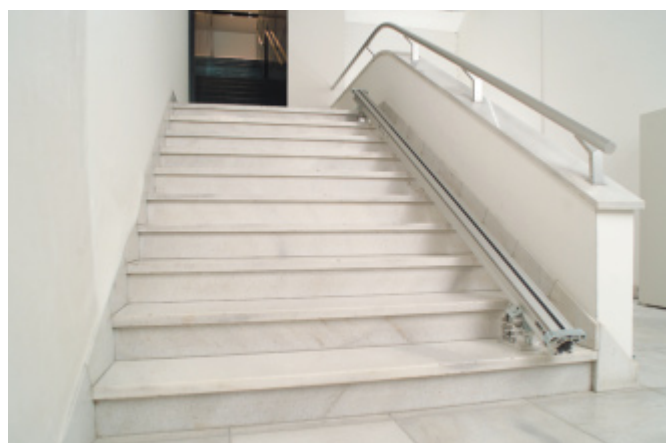

A [°]	B [inch]	C [inch]						
		Ø 26"	Ø 30"	Ø 32"	Ø 36"	Ø 42"	Ø 48"	Ø 64"
0°	9.39	10.76	12.84	13.87	15.95	19.06	22.17	30.46
5°	9.72	9.67	11.74	12.77	14.84	17.94	21.03	29.30
10°	10.15	8.49	10.53	11.55	13.59	16.65	19.72	27.89
15°	10.69	7.21	9.21	10.21	12.22	15.22	18.22	26.24
20°	11.35	5.85	7.80	8.77	10.72	13.65	16.57	24.36
25°	12.15	4.43	6.30	7.24	9.12	11.94	14.76	22.28
30°	13.13	2.94	4.74	5.63	7.43	10.12	12.82	20.00
35°	14.32	–	3.11	3.96	5.65	8.20	10.72	17.54
40°	15.78	–	–	2.22	3.81	6.19	8.58	14.93
45°	17.60	–	–	–	1.91	4.11	6.31	12.18

4.10 Extending the rail

NOTE

■ When long cuts are to be made, tapered connectors and eccentric pins can be used to join individual rails together to form a rigid unit.

1. Clean the tapered connector and connector sleeves.
2. Insert the tapered connector and secure it with an eccentric pin.
3. Slide the rail onto the tapered connector and also secure it with an eccentric pin.
4. To release the connection, turn the eccentric pins in the opposite direction and push out the tapered connector.



Parts

No.	Designation
①	Rail
②	Tapered connector
③	Eccentric pins
④	1/2" square drive wrench
⑤	Tapered sleeve

4.11 Mounting the saw head

NOTE

■ The DS-FCA-110 flush-cutting flange should be mounted on the saw head for flush-cutting applications.

1. Press the release button ② on the locking lever ① and push the locking lever downwards.
2. Position the saw head on the previously fastened rail.
3. Check that the guide rollers ③ are correctly aligned. The center of the guiding surface ④ should be in line with the middle of the guide roller.
4. Press the release button ② and pull the locking lever ① upwards.
5. Check the position of the guide rollers ③ (move the levers several times) and check that the clamping lever engages correctly before letting go of the saw head.



Parts

No.	Designation
①	Clamping lever
②	Release button
③	Guide roller
④	Guiding surface

Assembly

4.12 Adjusting the blade guard

1. Release the clamping screw ② on the saw arm.
2. Pivot the blade guard holder ① into the desired position.
3. Tighten the clamping screw ②.



Parts

No. Designation

- | | |
|---|---------------------------|
| ① | Blade guard holder |
| ② | Clamping screw |
| ③ | Hex. head wrench, 8 mm AF |

4.13 Connecting the power cable, remote control unit and cooling water hose to the power supply and saw head

CAUTION

- To avoid damage to the parts, check that the plug and socket are clean and in good condition before connecting. Clean the parts or remedy any damage before connecting them.
- When unplugging, always grip the plug and not the cable. Fit the protective cap immediately.
- Do not use the plug as a grip or carrying handle.
- Do not allow the cables to become tangled and place them carefully so that the plug connectors are not lying in water. The cables must be long enough to allow the saw head to move freely.

1. Remove the protective caps.
2. Align the plug carefully with the socket and push it in all the way without using excessive force.
3. Close the securing sleeve and check that it engages.
4. Close the protective caps together.
5. Connect the cooling water hose.

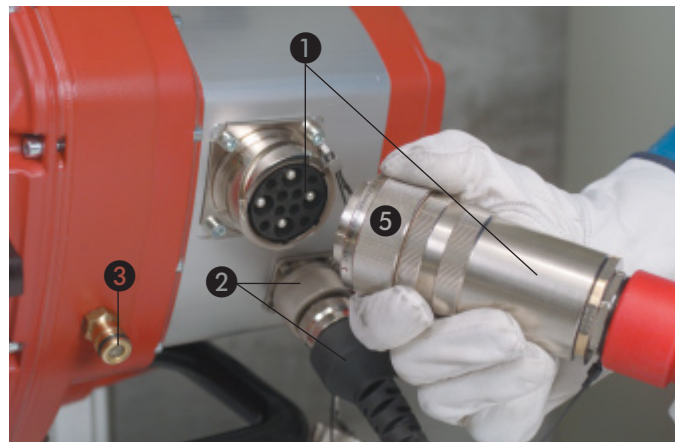

Parts

No. Designation

- | | |
|---|-------------------------------|
| ① | Power cable plug / socket |
| ② | Control cable plug / socket |
| ③ | Cooling water hose connectors |
| ④ | Protective cap |
| ⑤ | Securing sleeve |

4.14 Fitting the saw blade

NOTE

- Use the DS FCA flush-cutting flange and flush-cutting blade guard (available as accessories) for flush-cutting applications.
- Use only the original Hilti screw (10.9 grade steel) as the central blade mounting screw.
- Before operating the wall saw each time, always check the mounting flange and saw blade for damage, cracks or discoloration caused by overheating and clean the saw blade if it has been oiled or greased.

1. Position the saw blade ① on the saw arm, taking care to observe the correct direction of rotation.
2. Fit the blade flange ③ and mounting screw. Tighten the screw ④ only slightly.
3. Align the saw blade ① so that the mounting holes for flush cutting ⑤ lie between the water grooves.
4. Tighten the mounting screw ④ securely with the 19 mm box end wrench (110 Nm).

Parts

No.	Designation
①	Saw blade
②	Centering and mounting flange
③	Saw blade flange
④	Mounting screw
⑤	Mounting holes for flush cutting



Assembly

4.15 Fitting the blade guard

NOTE

- Should it prove impossible to use the blade guard due to specific circumstances at the working area, special measures must be taken, such as construction of a temporary enclosure (e.g. using forming boards), to protect the surrounding area from flying fragments etc. while sawing.
- Use the DS-FCA flush-cutting flange and flush-cutting blade guard (available as accessories) for flush-cutting applications.

CAUTION

Remove the side section only immediately before beginning a corner cut.

1. Push the center section of the blade guard ①, or the complete blade guard, onto the blade guard holder ④.
2. Insert the 2 side section locking hooks ③ in the fitting of the blade guard center section ①, attach the clamp ⑥ of the side sections to the middle section and secure blade guard to blade guard holder with rubber strap ⑧ onto the tensioning lug ⑦.
3. To remove the side section open clamp ⑥ and lift it out of middle section.

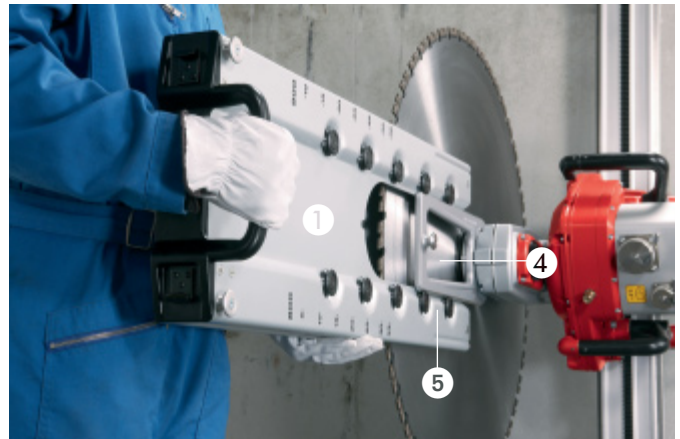

Parts

No. Designation

①	Blade guard center section
②	Blade guard side section
③	Guide pin
④	Blade guard holder
⑤	Guide rollers
⑥	Clamp
⑦	Tensioning lug
⑧	Rubber tensioning strap

5. Operation

5.1 Checks before beginning sawing

1. On-site preparations must be completed (supports, water collection, etc.).
2. The power supply must be positioned outside the danger zones. The areas in front of and behind the object where sawing is to take place are danger zones and must be secured and cordoned off. No persons may remain in a danger zone.
3. The power cable and water supply must be connected to the power supply. The power supply must be earthed / grounded and equipped with a ground fault circuit breaker. The water supply must be within the permitted pressure range.
4. The rail supports and rails must be aligned and fastened correctly, with all screws and nuts tightened securely.
5. The saw head must be mounted correctly and the locking levers engaged. Move the locking levers back and forward slightly to check that they are engaged correctly.
6. The power and control cables and water hoses must be laid out, connected correctly and the locking sleeves engaged.
7. The saw blade must be mounted in the correct direction of rotation and the mounting screw at the saw blade flange (or six countersunk screws for flush cutting) tightened securely.
8. The blade guard and end stop must be fitted securely.
9. The remote control unit and control cable must be connected.
10. The Output Stop switch on the remote control unit must be disengaged and reset.
11. All control knobs on the remote control unit must be in the "Off" or "Neutral" position.
12. The operator should be wearing the remote control unit (using the shoulder strap).
13. The "Ready" indicators on the power supply and remote control unit must light.
14. The safety precautions must be observed.

5.2 Description of the remote control unit

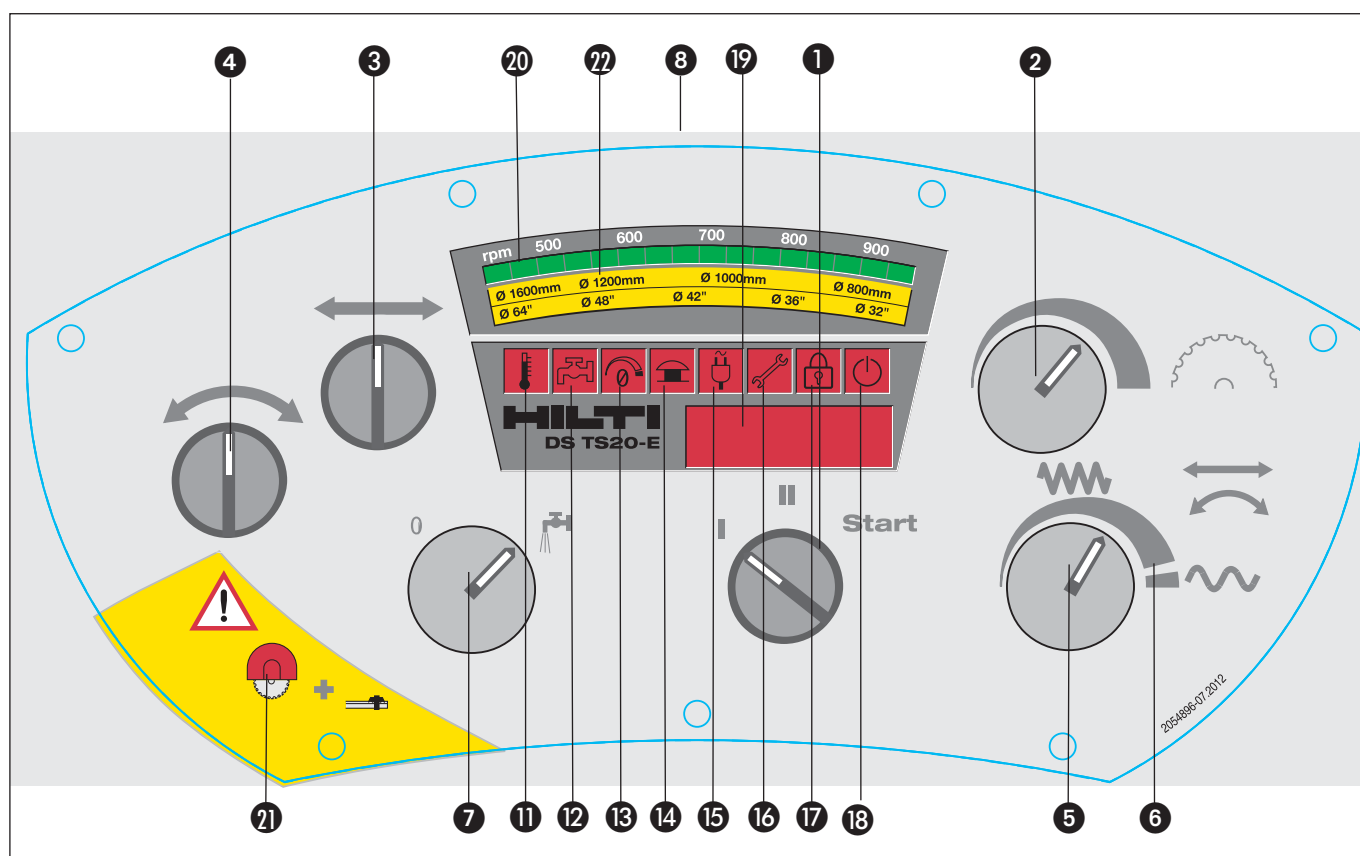

Operation



No.	Description	Function
①	Saw blade drive motor on / off	Starting blade drive: Turn to START (switch returns to position II when released) Position II = saw blade drive running Position I = saw blade drive "Off"
②	Saw blade speed	Infinite (stepless) speed regulation – display position ⑳.
③	Direction of advance	Selects direction of advance of the saw on the rail.
④	Direction of plunge movement	Selects direction of saw blade plunge movement.
⑤	Speed regulation for controls 3 and 4	Manual and / or automatic advance or plunge movement-display position ⑲.
⑥	Rapid movement for control 5	For rapid advance and plunge movement when saw blade drive is switched off.
⑦	Cooling water on / off	Controls cooling water supply to saw blade. Water flows when not under power.
⑧	Output Stop switch	Press in an emergency! Leave pressed in when setting up or changing blades etc. Turn knob in direction of arrow to release – display position ⑭.
⑨	Reset switch for Output Stop	Reset must be pressed after releasing the Output Stop switch ⑧ – display position ⑱.
⑪	Overheating cut-out	Lights when the machine has switched itself off due to overheating.
⑫	Temperature warning	Lights when cooling is inadequate.
⑬	Zero position error	Lights when one or more knobs are not in the zero or neutral position when switching on.
⑭	Output Stop indicator	Lights when the Output Stop switch is pressed or when not reset.
⑮	Fault in electric supply	Lights when a phase is missing, voltage is too low or too high or out of synchronization.
⑯	Service indicator	Lights when servicing is due (end of service interval). Servicing should be carried out by Hilti.
⑰	Theft protection	Not active.
⑱	Output Stop indicator	Lights when the Output Stop has not been reset – switch ⑨.

19	Operating hours counter	After switching on, the total number of hours that the saw head has been in operation is displayed.
	Power indicator	The actual power input is displayed during operation of the saw (in %).
	Supply voltage	During operation, turn starting switch 1 to "Start" (voltage is displayed).
	Fault indicator	The code displayed can help to localize a possible fault (e.g. Er01).
20	Speed indicator	Can be adjusted by the knob at position 2.
21	Warning	Operation of the saw without blade guard and end stops fitted is not permissible!
22	Recommended speed range	

NOTE

To read the mains input voltage while the saw is in operation, proceed as follows:

1. Turn the starting switch 1 to the "Start" position and hold it there.
2. The voltage reading is shown in the display 19 in volts.

To read the mains input voltage while the saw is stationary, proceed as follows:

1. Turn the starting switch 1 to the "I" position.
2. Set the saw blade speed control knob 2 to the maximum speed position.
3. Turn the starting switch 1 to the "Start" position and hold it there.
4. The voltage reading is shown in the display 19 in volts.

The procedure described below can be used to reverse the positions of the switch controlling direction of advance:

1. Turn the starting switch 1 to the "I" position.
2. Set the advance speed control knob 5 to the zero position.
3. Set the saw blade speed control knob 2 to the maximum speed position.
4. Operate the direction of movement control switch 3 or 4.
5. Turn the starting switch 1 to the "Start" position and hold it there.
6. When reversal of control direction has been successful, "L__R" is shown in the display 19.

5.3 Operating the saw

1. Use the plunge 4 and advance 3 controls and the speed regulation knob 5 to move the saw head along the rail to where the cut is to be started and then return all switches / knobs to the "Neutral" or "Zero" position. For rapid movement, turn the speed regulation knob 5 to the right, beyond the pressure point 6, as far as it will go.
2. Switch on the cooling water 7.
3. Switch on the saw blade drive 1 and then use the speed control 2 to set the desired speed (please observe recommended speeds). Wait until the blade runs up to speed.
4. Select the direction of plunge movement 4 and advance speed 5 and then bring the blade slowly to the desired cutting depth (cut into the concrete). Set the plunge movement 4 and speed regulator 5 back to the "Neutral" or "Zero" position when the desired depth has been reached.
5. Select the direction of longitudinal advance 3 and the desired speed 5, e.g. 100%. Make the initial cut at reduced power (60%).
6. At the end of the cut, turn the speed control 5 to the "Zero" position and switch off the longitudinal advance 3.
7. Repeat steps 4 to 6 until the desired depth is reached.
8. Once the cut has been completed or the maximum depth reached, use the plunge movement direction control 4 to lift the saw blade out of the kerf while the blade is still rotating, bringing the saw and saw arm to the 90° position.

Operation

- Subsequently turn all switches / knobs (advance direction, advance speed, blade speed, water supply and starting switch) back the "Neutral" or "Zero" position and then press the Output Stop switch.
- If necessary, fit a larger diameter saw blade (max. 64" / 1600 mm dia.) and repeat the procedure.

5.4 Guidelines and guide values

1. The initial or guide cut

The initial cut is also known as the guide cut. This cut should always be made with the saw arm in the trailing position. Depending on the material being cut (hard, soft or masonry) the guide cut should be made to a depth of between 1.5" and 2" (4 and 5 cm). The guide cut should always be made at reduced power (e.g. 60%). This prevents the blade wandering off course and ensures a straight cut.

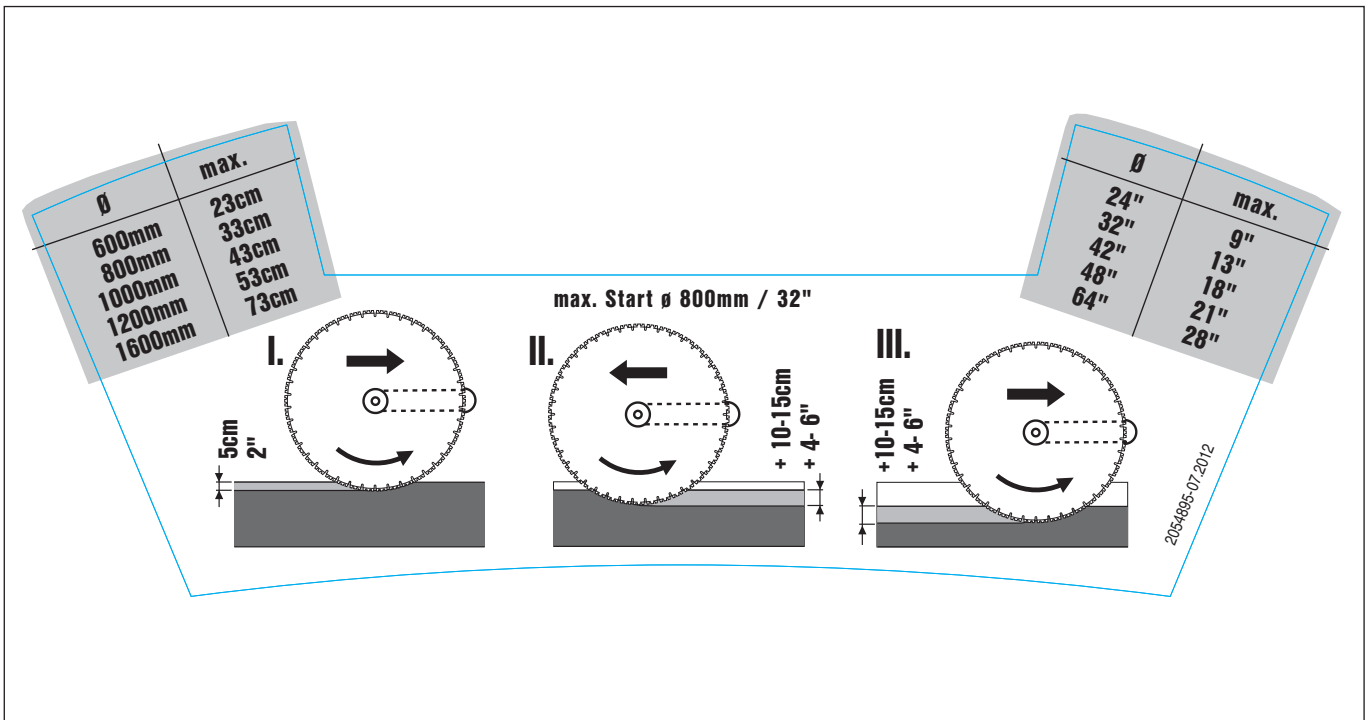

2. Subsequent cuts

After the guide cut has been made, sawing can continue with the saw arm in either the trailing position (pulling the blade) or leading position (pushing the blade). The depth of subsequent cuts again depends greatly on the material, but may be between 4" and 6" (10 and 15 cm). These cuts can be made at full (100%) power.

5.5 Remaining cutting distances with the DS TS20-E saw head

S [inch]	A [inch]						
	Ø 26"	Ø 30"	Ø 32"	Ø 36"	Ø 42"	Ø 48"	Ø 64"
9	7.21	5.54	5.03	4.28	3.53	3.02	2.24
12		11.80	9.53	7.60	6.01	5.04	3.66
15			14.54	9.73	10.20	6.09	5.49
18					17.28	11.91	7.83
21						20.03	10.85

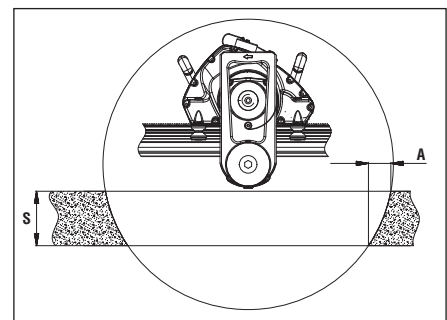

5.6 Dismantling the saw system

1. Pivot the saw arm to the 90° position. Switch the machine off, disconnect the cables and fit the protective caps to the plugs and sockets.
2. Disconnect the water hose from the saw head and clean the blade guard, saw head and rail system.
3. Remove and clean the blade guard and saw blade.
4. Remove the saw head from the rail and clean these parts.
5. Disconnect the cables and water hose from the power supply and fit the protective caps to the plugs and sockets.
6. Clean the cables and hoses, roll them up and attach them securely to the transport trolley.
7. Stow the saw head, rail system parts, blade guard and accessories securely on the transport trolley.

CAUTION

- To avoid the possibility of damage, always switch off at the main switch before disconnecting the power cable.
- To avoid damage when temperatures below freezing are expected, the cooling system must be fully drained by blowing out with the pump provided.

6. Maintenance

6.1 Cleaning

1. Disconnect the system from the electric supply.
2. Clean the entire set of equipment after finishing work or before long breaks between periods of use.
3. Do not allow dirt and slurry to dry out and adhere to the parts.
4. When cleaning, pay particular attention to the operating surfaces, threads, connectors, toothed sections, points of contact between moving parts, operating controls and safety or operating information plates.
5. Fit the protective caps to all plugs and connectors.
6. Clean the power supply, remote control unit, and cable with a damp cloth.
7. Use a medium-hard brush and water to clean the saw head, rails, blade guard system and transport trolley.

CAUTION

- Do not use high pressure cleaning systems to clean the power supply, saw head, remote control unit or cables. Water finding its way into these parts may cause malfunctions and damage to the equipment.
- If concrete formwork parting agent or oil is used on the equipment (to help prevent concrete adhering to it) take care to ensure that the product used contains no solvents.
- Products containing solvents may attack and damage the seals or other parts of the casing.

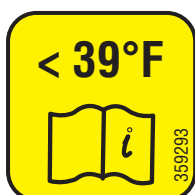

To avoid damage when temperatures below freezing are expected, the cooling system must be fully drained by blowing out with the pump provided.

Maintenance

6.2 Maintenance

Parts	Procedure	Daily	Weekly
Rail supports	Check the contact and clamping surfaces, clean if necessary.	●	
	Check the threads for smoothness and ease of operation, clean and grease if necessary.		●
Rails	Check the contact and running surfaces, clean if necessary.	●	
	Check the tothing for damage and wear, replace the rail if necessary.		●
	Check the tapered sleeves, clean and lubricate with oil if necessary.	●	
Blade guard	Check and clean working parts and all inside and outside surfaces.	●	
	Check the guide rollers for easy operation and clean or replace the parts if necessary.		●
	Check the condition of the tensioning straps and replace them if necessary.	●	
Saw head	Check the locking mechanism for security of engagement, have it repaired if necessary	●	
	Check the guide rollers for ease of operation and excessive play, have them replaced / repaired as necessary.		●
	Check the plug connectors for cleanliness and damage. Blow out with compressed air or have the parts replaced if necessary.	●	
	Check the saw blade mounting flange and mounting screw, clean or replace if necessary.	●	
	Check the saw head for oil or water leakage and have it repaired if necessary.		●
	Check the water flow and replace the mesh filter at the water supply connection if necessary.		●
Power supply	Check the switches and indicator lamps for correct operation and have them replaced if necessary.	●	
	Check the plug connectors for cleanliness and damage. Blow out with compressed air or have the parts replaced if necessary.	●	
	Check the power supply for water leakage and have it repaired if necessary.		●
	Check the water flow and replace the mesh filter at the water supply connection and descale if necessary.		●
Remote control unit	Check the switches and indicator lamps for correct operation.		
	Clean the parts or have them replaced if necessary.	●	
	Check the plug connectors for cleanliness and damage. Blow out with compressed air or have the parts replaced if necessary.	●	
Water hose	Check the couplings for cleanliness, ease of operation and leakage.		
	Clean and lubricate the couplings if necessary (lubricant spray).	●	
	Check the hose for leakage.		●
Cables / plugs	Check the plug connectors for cleanliness, damage and ease of operation. Blow out with compressed air or have the parts replaced if necessary.	●	
	Check the cables for damage and replace them if necessary.	●	
Transport trolley	Check the tyre pressure (2.1 bar or 30 psi).		●
Tool set	Check for completeness.		●

6.3 Service intervals

We recommend that the system is checked at a Hilti service center after every 200 operating hours. This will ensure that the equipment is ready for use when required and help avoid high subsequent costs.

NOTE







The service indicator lights when servicing is necessary.

7. Troubleshooting











7.1 The meaning of error codes and the measures to be taken to remedy faults

The electric wall saw is quipped with a fault diagnosis and error display system that allows the operator to localize faults and, as far as possible, to remedy these without assistance.

Should it prove impossible to remedy the fault yourself, you can assist Hilt Service by describing the fault as precisely as possible and by stating the error code displayed by the remote control unit.

Displayed on remote control	Fault	Possible cause	Recommended measures to remedy fault
No display	No display on power supply or remote control unit	Electric supply not connected or faulty	<ul style="list-style-type: none"> – Check the electric supply – Check the plug connections – Return the remote control and power supply to Hilti Service
Symbol 11 lights 	Er50 Er51 Er52 Er53 Machine has switched itself off due to overheating	Cooling water insufficient or too warm	<ul style="list-style-type: none"> – Allow to cool with cooling water flowing / restart – Return the saw head to Hilti Service
Symbol 11 lights 	Er20 Er21 Machine cannot be switched on	Temperature sensor in the saw head is faulty	<ul style="list-style-type: none"> – Return the saw head to Hilti Service
Symbol 11 lights 	Er89 Er90 Machine cannot be switched on	Temperature sensor in the power supply is faulty	<ul style="list-style-type: none"> – Return the power supply to Hilti Service
Symbol 12 lights 	Er54 Er55 Er56 Warning before cut-out due to overheating	Cooling water insufficient or too warm – power supply is overheating	<ul style="list-style-type: none"> – Improve the cooling – Return the power supply to Hilti Service
Symbol 12 blinks slowly 	Sr60 Sr61 Warning before cut-out due to overheating	Main motor or advance motor is overheating	<ul style="list-style-type: none"> – Improve the cooling – Observe the application guidelines – Return the saw head to Hilti Service
Symbol 12 blinks rapidly 	Sr60 Sr61 Warning of imminent cut-out due to overheating	Main motor or advance motor is overheating	<ul style="list-style-type: none"> – Improve the cooling – Observe the application guidelines – Return the saw head to Hilti Service
Symbol 12 blinks slowly 	Sr62 Sr63 Sr64 Warning before cut-out due to overheating	Cooling water insufficient or too warm Ambient temperature too high (Sr64)	<ul style="list-style-type: none"> – Improve the cooling – Place the power supply in the shade – Return the saw head to Hilti Service

Troubleshooting

Symbol 12 blinks rapidly 	Sr62 Sr63 Sr64	Warning of imminent cut-out due to overheating	Cooling water insufficient or too warm Ambient temperature too high (Sr64)	<ul style="list-style-type: none"> – Improve the cooling – Place the power supply in the shade – Return the saw head to Hilti Service
Symbol 13 lights 		Saw blade drive cannot be switched on	One or more control knobs or switches not in the "0" or neutral position	<ul style="list-style-type: none"> – Return all knobs and switches to the "0" or neutral position and restart
Symbol 13 lights 		Advance movement doesn't function	Longitudinal and plunge advance operated simultaneously	<ul style="list-style-type: none"> – Operate the advance controls individually
Symbol 13 lights 		Zero position indicator lights as the blade is coming to a standstill	The motor brake has been activated	<ul style="list-style-type: none"> – None required
Symbol 14 lights 		Machine cannot be switched on	The Output Stop switch is in the pressed-in position	<ul style="list-style-type: none"> – Release the Output Stop button / restart – Have the fault repaired by Hilti Service
Symbol 14 lights 	Er11	Machine cannot be switched on	Break in the Output Stop / motor cable circuit	<ul style="list-style-type: none"> – Check the motor cable and plug connections – Return the saw head, motor cable and power supply to Hilti Service
Symbol 15 blinks 	Er44	Machine cannot be switched on or switches itself off	Difference between phases > 10%	<ul style="list-style-type: none"> – Check the electric supply – Return the power supply to Hilti Service
Symbol 15 lights 	Er42 Er43	Machine cannot be switched on or switches itself off	Electric power is inadequate	<ul style="list-style-type: none"> – Check the electric supply – Return the power supply to Hilti Service
Symbol 15 blinks slowly 	Sr45 Sr46	Warning that electric power is inadequate	Electric power is inadequate	<ul style="list-style-type: none"> – Check the electric supply – Return the power supply to Hilti Service
Symbol 16 lights 		No fault	Service interval has been reached	<ul style="list-style-type: none"> – Return the saw head to Hilti for servicing
Symbol 18 lights 		Machine cannot be switched on	Output Stop reset button hasn't been pressed	<ul style="list-style-type: none"> – Press the reset button / restart
Display	Er00	The machine doesn't function	Remote control unit and saw head not compatible with each other	<ul style="list-style-type: none"> – Check compatibility and replace the remote control unit with one of the correct type – Return remote control and power supply to Hilti Service
Display	Er01 Er02	The machine doesn't function correctly	Faulty connection between the remote control and power supply	<ul style="list-style-type: none"> – Check plug connectors and cable – Replace the remote control unit – Return remote control and power supply to Hilti Service
Display	Er04 Er05 Er06 Er07	The machine doesn't function correctly	Fault in the remote control electronics	<ul style="list-style-type: none"> – Replace the remote control – Return the remote control to Hilti Service
Display	Er12	Machine cannot be switched on	Break in the connection between the power supply and the saw head	<ul style="list-style-type: none"> – Check the control cable and plug connections – Return the saw head, control cable and power supply to Hilti Service

Display	Er30	The machine has switched itself off	The slip clutch has been activated as a result of how the saw is being used	<ul style="list-style-type: none"> – Observe the application guidelines – Return the saw head to Hilti Service
Display	Er33	The machine has switched itself off	Saw used incorrectly - overload Saw blade stuck Short circuit	<ul style="list-style-type: none"> – Observe the application guidelines – Return the saw head, cable and power supply to Hilti Service
Display	Er35	The machine has switched itself off	Saw used incorrectly Excessive lateral friction Blade segments polished	<ul style="list-style-type: none"> – Observe the application guidelines – Return the power supply to Hilti Service
Display	Er36	Saw blade cannot rotate	Saw blade stuck	<ul style="list-style-type: none"> – Release the blade / restart – Return the power supply to Hilti Service
Display	Er40	The machine has switched itself off	Electric supply voltage too high	– Check the electric supply
Display	Er41	The machine has switched itself off	Electric supply voltage too low	– Check the electric supply
Display	Er80	The machine doesn't function correctly	Electronic fault in the power supply	– Return the power supply to Hilti Service
Display	Er81 Er82	The machine doesn't function	Electronic fault in the power supply	– Return the power supply to Hilti Service
Display	Er83 Er84	The machine doesn't function	Electronic fault in the power supply	– Return the power supply to Hilti Service
Display	Er85 Er86 Er87 Er88	Machine cannot be switched on	Contactors K1 or K2 in the power supply is faulty	– Return the power supply to Hilti Service
Display	Er91	The machine doesn't function	Safety loop for Output Stop is faulty	<ul style="list-style-type: none"> – Replace the remote control – Return power supply to Hilti Service

7.2 Causes of faults with no error code and how they can be remedied

Description of fault	Possible cause	Recommended measures to remedy the fault
Blade wanders off course	Inadequate blade tension	Check the tension / replace the blade
	Saw blade segments have lost cutting power	Check the specification / replace the blade
	No guide cut made or guide cut not straight	Observe instructions and guide values
	Play at the guide rollers	Check the play / replace the rollers or rail
	Rail not securely fastened	Check and improve the fastenings
	Rail distorts (twists)	Install additional rail supports
Low sawing performance	Unsuitable saw blade specification	Check the specification / change to other specification if possible
	Depth of cut too high	Check depth of cut / reduce if possible
	Power setting too low	Check the setting / increase if possible
	The machine is not receiving enough current	Check the setting / increase if possible
	Drop in performance due to wandering off course	See "Blade wanders off course"
	Drop in performance due to high reinforcement content	Check the reinforcement content / change position of cut if possible
	Saw blade speed too high or too low	Check the speed / increase or reduce if possible

Troubleshooting

7.3 Repairs

CAUTION

- The machine may be operated, serviced and repaired only by authorized personnel who have been trained by Hilti. This personnel must be informed of any special hazards that may be encountered.
- Repairs to electrical components may be carried out only by trained electrical specialists.
- NEVER open the covers on the machine while on a construction site.
- The capacitors in the power supply retain a voltage for approx. 2 minutes after disconnection from the electric supply.

8. Accessories

Item no.	Designation	Use
284808	DS-R100-L rail	Saw guidance (3.3 ft)
284809	DS-R200-L rail	Saw guidance (6.5 ft)
284810	DS-R230-L rail	Saw guidance (7.5 ft)
371703	DS-ES-L end stop	Safety stop for saw head
207137	DS-CP-ML rail clamp	Fastening rails
273336	DS-RF-L rail support	Fastening rails
273337	DS-RFP-L rail support	Fastening rails for angled and stepped cuts
232241	D-CO-ML double taper	Extending rails
232244	D-EP-ML eccentric pin	Extending rails

Item no.	Designation	Use
238000	DS-BG65 blade guard	Blade guard for blades up to 26" (650 mm) dia.
2051935	DST-BG 80 blade guard	Blade guard for 24" to 36" (600 to 800 mm) dia. saw blades
238002	DS-BG80 center section	Blade guard for 24" to 36" (600 to 900 mm) dia. saw blades*
238003	DS-BG80 side section	Blade guard for 24" to 36" (600 to 900) mm dia. saw blades
238004	DS-BG120 center section	Blade guard for 40" to 48" (1000 to 1200 mm) dia.
238005	DS-BG120 side section	Blade guard for 40" to 48" (1000 to 1200 mm) dia.
2064904	DS-BG160 blade guard	Blade guard for 59" to 63" (1500 to 1600 mm) dia. saw blades

Item no.	Designation	Use
238006	DS-BGF80 center section	Blade guard for 24" to 36" (600 to 900 mm) dia. saw blades for flush cutting *
238007	DS-BGF80 side section	Blade guard for 24" to 36" (600 to 900 mm) dia. saw blades for flush cutting
238008	DS-BGF120 center section	Blade guard for 40" to 48" (1000 to 1200 mm) dia. saw blades for flush cutting *
238009	DS-BGF120 side section	Blade guard for 40" to 48" (1000 to 1200 mm) dia. saw blades for flush cutting
256237	DS-BGF 160S blade guard	Blade guard for 59" to 63" (1500 to 1600 mm) dia. saw blades

Item no.	Designation	Use
416193	DS-FCA-1"/88.9 flush-cutting flange	Saw blade mounting flange for flush cutting*
416189	DS-FCA-1"/88.9 flange assy	Saw blade mounting flange for flush cutting

* Only to be used with the corresponding side sections!

Item no.	Designation	Use
40102	DS TS tool set	Fastening rails, personal protection, maintenance and operation

Item no.	Designation	Use
206856	DS TS20-E power cable, 33 ft (10 m)	System cable
206857	DS TS20-E control cable, 33 ft (10 m)	System cable
400768	RC extension cable	Extending distance between remote control and power supply 33 ⇔ 66 ft (10 ⇔ 20 m)
228150	Water hose, 33 ft (10 m)	System water hose

9. Manufacturer's warranty – tools

Hilti warrants that the tool supplied is free of defects in material and workmanship. This warranty is valid so long as the tool is operated and handled correctly, cleaned and serviced properly and in accordance with the Hilti Operating Instructions, and the technical system is maintained. This means that only original Hilti consumables, components and spare parts may be used in the tool.

This warranty provides the free-of-charge repair or replacement of defective parts only over the entire lifespan of the tool. Parts requiring repair or replacement as a result of normal wear and tear are not covered by this warranty.

Additional claims are excluded, unless stringent national rules prohibit such exclusion. In particular, Hilti is not obligated for direct, indirect, incidental or consequential damages, losses or expenses in connection with, or by reason of, the use of, or inability to use the tool for any purpose. Implied warranties of merchantability or fitness for a particular purpose are specifically excluded.

For repair or replacement, send tool or related parts immediately upon discovery of the defect to the address of the local Hilti marketing organization provided.

This constitutes Hilti's entire obligation with regard to warranty and supersedes all prior or contemporaneous comments and oral or written agreements concerning warranties.





Hilti Corporation
LI-9494 Schaan
Tel.: +423 234 21 11
Fax: +423 234 29 65
www.hilti.group



2164701



Hilti Connect



2074465